

# HVAC Air Duct Leakage



Presented By:  
Mark Terzigni  
Project Manager  
Technical Services  
SMACNA

# What is “Duct Leakage”

---

- Duct leakage is the leakage of air from **DUCT**
- Equipment leakage is the leakage of air from **EQUIPMENT**
- Accessory leakage is the leakage of air from **ACCESSORIES**



# System Leakage

---

- HVAC Air System Leakage is the **combination** of duct, equipment and accessory leakage.
- DUCT leakage is not SYSTEM leakage



# Equipment Leakage Test

---

- **SPC 193P Proposed Standard authorized September 30, 2006. Method of Testing for Determining the Air-Leakage Rate of HVAC Equipment (Revised TPS approved 10/6/07).**
- **1. PURPOSE:**
- **This standard prescribes a method of testing to determine the air-leakage rate of forced-air heating, and cooling HVAC equipment, prior to field installation.**



# Equipment Leakage Test

---

- **2. SCOPE:**
- **2.1 This standard applies to the following:**
  - a. Equipment intended for installation in ducted systems, including furnaces, heat pumps, air conditioners, coil boxes, filter boxes, and associated components.
  - b. Equipment that moves less than 3000 cfm (1400 L/S) of air.
- **2.2 It does not apply to field installed components, such as plenums or ducts.**



# Definitions

---

- Transverse Joint: Includes Duct to Duct, Duct to Branch, Duct to Tap, Duct to Fitting

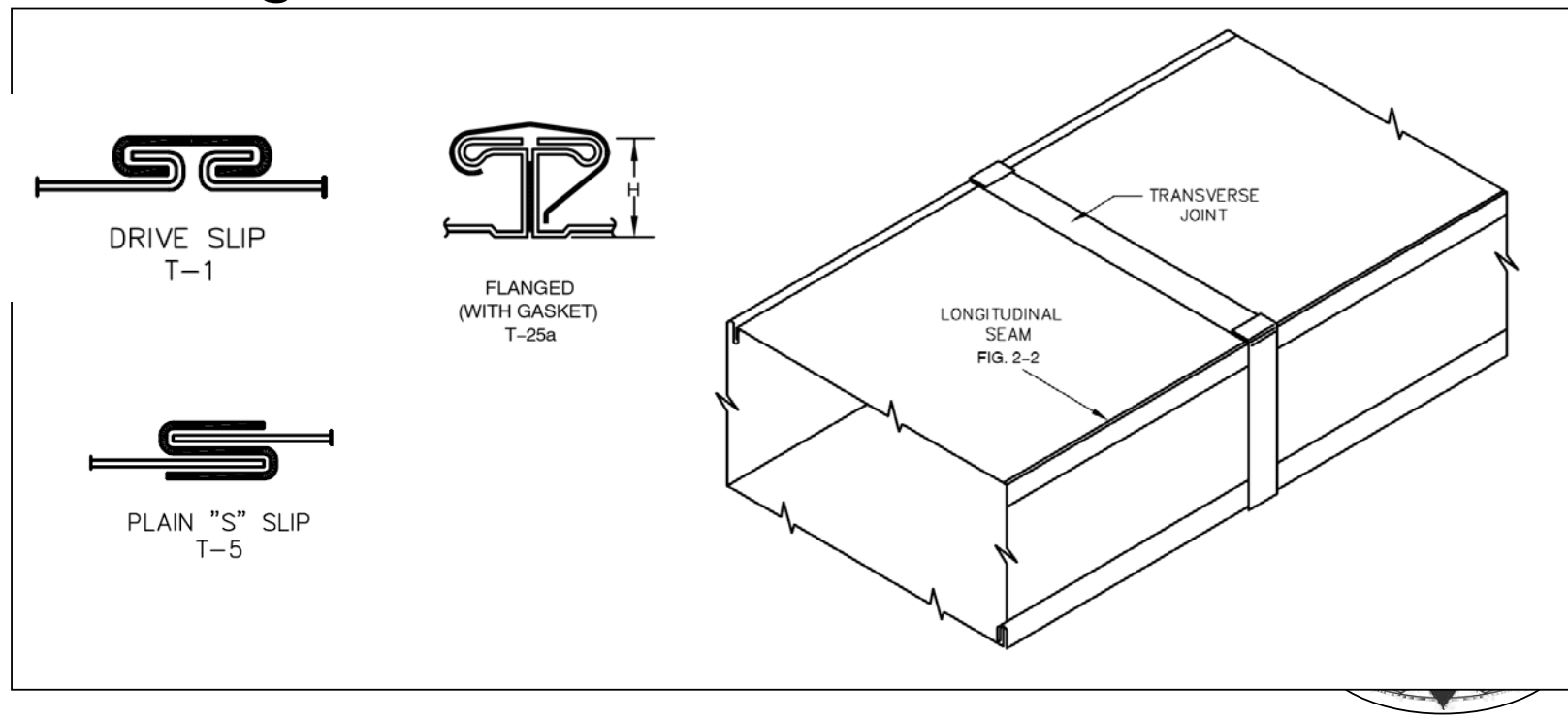

# Definitions

- Longitudinal Seam: The joining of two edges oriented in the direction of the airflow. (Spiral seams are exempt from sealing)

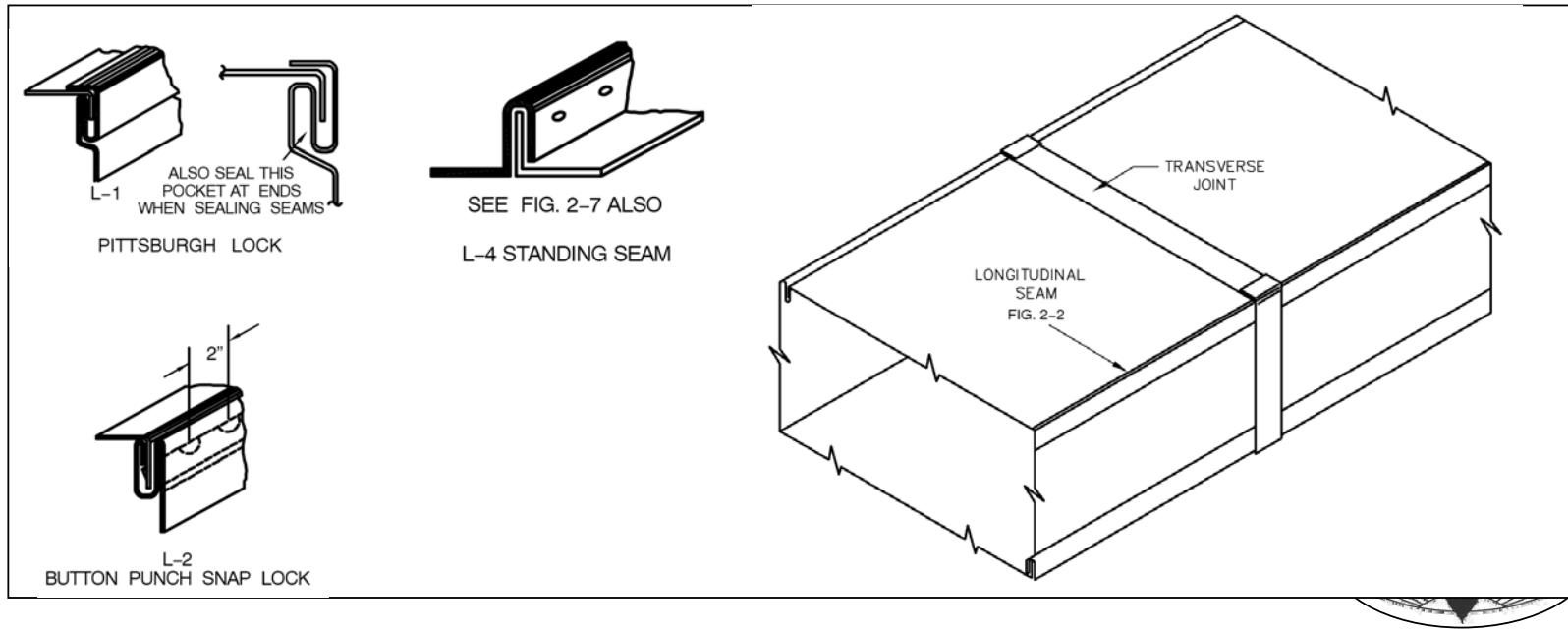

# Definitions

---

- Penetration: Rod, wire, and tubing.
- The following are not considered penetrations in the context of leakage testing...Screws and other fasteners, and control rods for dampers. These are not required to be sealed to meet seal class A.





# Duct Leakage Factors

---

- The factors that determine how much a given duct leaks
  - Type of construction (seam choices)
  - The amount of seams and joints (amount of duct)
  - Static pressure
  - Openings / penetrations
  - Sealant
  - Workmanship



# How to Predict Duct Leakage

---

- ▣ Testing by SMACNA/ASHRAE/TIMA and other organizations in Europe shows that many of the previous factors can be accurately estimated by using the duct surface area.

$$F = C_L P^N$$



# Leakage Equation

---

- **F** is the predicted leakage expressed as a volume per unit area (CFM/100 ft<sup>2</sup> of duct surface area)
- **C<sub>L</sub>** is a constant called the leakage class
  - Based on type of construction and sealing methods. Determined through testing.
- **P** is the static pressure (in. w.g.)
- **N** is a dimensionless exponent determined through testing (0.65)



# Seal Class

---

- ❑ There are 3 seal classes.
- ❑ Class C requires that only transverse joints be sealed
- ❑ Class B requires that transverse joints and longitudinal seams be sealed (spiral seams are excluded)
- ❑ Class A requires that transverse seams, longitudinal seams and all applicable penetrations be sealed.



# Seal Class

---

- ❑ Seal class defines where sealant is applied.
- ❑ Seal Class does not solely determine the air leakage for duct.
- ❑ In other words, going from seal class C to seal class A can reduce the amount of leakage but there is no data that supports how much the leakage will be reduced. Other factors such as seam choices impact leakage rates.



# Duct Construction Standards

---

- ❑ Current Standard ANSI/SMACNA HVAC DUCT CONSTRUCTION STANDARDS METAL AND FLEXIBLE THIRD EDITION
- ❑ Pressure Classes (as shown on the contract drawings) ½, 1, 2, 3, 4, 6, 10 in. w.g.
- ❑ Duct sealed in accordance with Table 1-1 in the HVAC Air Duct Leakage Test Manual



# Sealing Requirements

---

SEAL CLASS	Sealing Requirements	Applicable Static Pressure Construction Class
A	All Transverse joints, longitudinal seams, and duct wall penetrations	4" wg and up (1000 Pa)
B	All Transverse joints and longitudinal seams only	3" wg (750 Pa)
C	Transverse joints only	2" wg (500 Pa)

In addition to the above, any variable air volume system duct of 1" (250 Pa) and ½" wg (125 Pa) construction class that is upstream of the VAV boxes shall meet Seal Class C.

**Table 1-1 Standard Duct Sealing Requirements**



# Pressure Class-Seal Class-Leakage Class

---

DUCT CLASS	½", 1", 2" wg	3" wg	4", 6", 10" wg
SEAL CLASS	C	B	A
SEALING APPLICABLE	TRANSVERSE JOINTS ONLY	TRANSVERSE JOINTS AND SEAMS	JOINTS, SEAMS AND ALL WALL PENETRATIONS
<b>LEAKAGE CLASS</b>			
RECTANGULAR METAL	24	12	6
ROUND METAL	12	6	3

**Table 4-1 Applicable Leakage Classes**





# Sealants

---

## □ Liquids

- Consistency of heavy syrup
- Applied by brush, cartridge gun, or powered pump
- Can be water based or solvent based
- Typically used on slip joints
- Also used on “coil lines”



# Sealants

---

## □ Mastics

- Thick consistency, suitable for fillet applications, in “groves” and between flanges.
- Excellent adhesion and elasticity



# Sealants

---

## □ Gaskets

- Foam, or neoprene type should have adhesive backing for ease of installation
- Butyl gaskets typically extruded to shape remains flexible. Consistency similar to “silly putty”
- Both types typically used between flange joints



# Sealants

---

## □ Tapes

- Closures listed as components of systems complying with UL 181
- No recognized Industry Performance Standards that set forth:
  - Peel adhesion or shear adhesion
  - Tensile strength
  - Temperature limits
  - Accelerated aging



# Sealants

---

## □ Tapes

- Some test results published in the product directories of the Pressure Sensitive Tape Council (Glenview, Illinois)
- Shelf life can be difficult to assess
- Aging characteristics (what happens to the tape in 10 or 20 years)
- Compatibility with duct materials flexible non metallic ducts



# Sealants

---

- LEED® compliance
  - LEED® adopted South Coast Air Quality Management Divisions (SCAQMD) Rule 1168 with regards to “acceptable” sealants.
  - Rule 1168 does not specifically address duct sealant
  - Which category did duct sealant fall under Architectural Sealants or OTHER?



# Sealants

---

## □ LEED®

- According to SCAQMD duct sealants were to be classified as an architectural sealant.
- Does this matter?-Most definitely
- Architectural sealants have a VOC limit of 250 g/l Other allows 420 g/l
- Almost every commercially available solvent based duct sealer has a VOC content around 300 g/l



# Sealants

---

## □ LEED®

- Why not use water based duct sealants all of the time?
- Water based duct sealants can not be properly applied when temperatures are below 40°F (5°C) – not an issue in Southern California, but what about the rest of the world





# Sealants

---

## □ LEED®

- Acetone is listed as “exempt” from VOC per the EPA
- There are several 100% acetone based duct sealers available that can be applied below 40°F (5°C) that have “zero reportable VOC’s”



# Sealants

---

## □ LEED®

- UPDATE After several discussions between SMACNA and the USGBC the following occurred;
- A Credit Interpretation Request (CIR) was issued "How does a project team classify duct sealants for application under EQc4.1?"
- The response: "Project teams may classify duct sealants under "Other", as listed in the SCAQMD VOC Limits table."



# Sealants

---

## □ LEED®

- This ruling allows the proper sealing of ductwork to be LEED compliant under typical conditions for areas outside of Southern California.
- In keeping with SMACNA's Policy on sustainability, using products with the least environmental impact for the intended application and jobsite conditions is encouraged.



# Duct System Designer

---

- ❑ Match the fan to system's pressure and airflow requirements
- ❑ Account for equipment leakage
- ❑ Account for accessory leakage
- ❑ Account for duct leakage
- ❑ Specify the proper pressure class
- ❑ Specify the amount and manner of duct air leakage testing.



# Leakage Tests

---

- Need to verify leakage control by field testing is not present when adequate methods of sealing and assembly are used.
- It is not recommended to test duct systems below 3 in. w.g. static pressure.



# Leakage Tests

---

- ❑ The designer must clearly designate what section(s) of the system require testing. "All ductwork" is usually impractical.
- ❑ The designer must also specify the appropriate test methods



# Leakage Tests

---

## □ ASHRAE 90.1

- Generally requires testing on systems at 3 in. w.g. and above various seal classes used.

## □ ASHRAE 189 (proposed)

- Will likely require seal class "A" for all duct. No testing is required. (Inspection)



# Leakage Tests

---

## □ IECC

**503.2.7.1.3 High-pressure duct systems.** Ducts designed to operate at static pressures in excess of 3 inches w.g. (746 Pa) shall be insulated and sealed in accordance with Section 503.2.7. In addition, ducts and plenums shall be leak-tested in accordance with the SMACNA *HVAC Air Duct Leakage Test Manual* with the rate of air leakage (*CL*) less than or equal to 6.0 as determined in accordance with Equation 5-2.

$$CL = F \times P^{0.65} \qquad \text{(Equation 5-2)}$$

where:

*F* = The measured leakage rate in cfm per 100 square feet of duct surface.

*P* = The static pressure of the test.





# Leakage Tests

---

## □ IECC

- 25% of the system (based on surface area must be tested for systems in excess of 3 in. w.g.)
- All ducts require a minimum of seal class "B" (joints and seams)



# Air Leakage Misconceptions

---

- Just add sealant to get lower leakage rates
  - Striving for a “tight” duct system is fine, but if the designer specifies impractical leakage rates there can be a significant increase in the cost of constructing the duct.



# Air Leakage Misconceptions

---

- If the leakage test shows a leakage rate of 100 CFM then the system must leak 100 CFM
  - Not true. Leakage tests are performed at a specific static pressure throughout entire sections of a duct system. Under operating conditions the static pressure typically drops as you move through the system.



# Air Leakage Misconceptions

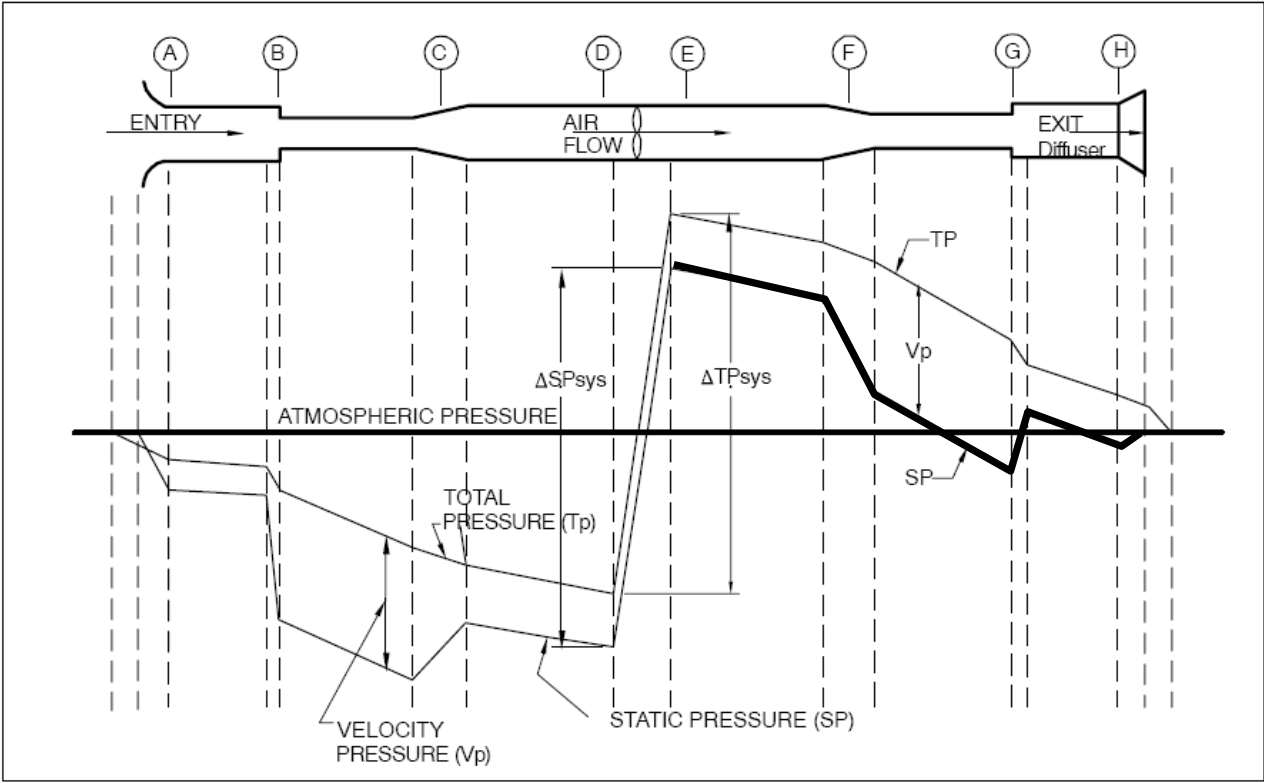

# Air Leakage Misconceptions

---

## □ Mean pressure:

- Standards in Europe utilize the concept of mean pressure for duct testing.
  - Example: The “high pressure” portion of a duct system requires 4 in. w.g. at the fan but only 2 in. w.g. at the VAV boxes. The test pressure would be 3 in. w.g.  $[(4+2)/2 = 3]$
- The goal is to make test conditions closer to operating conditions.



# Testing Layout

---

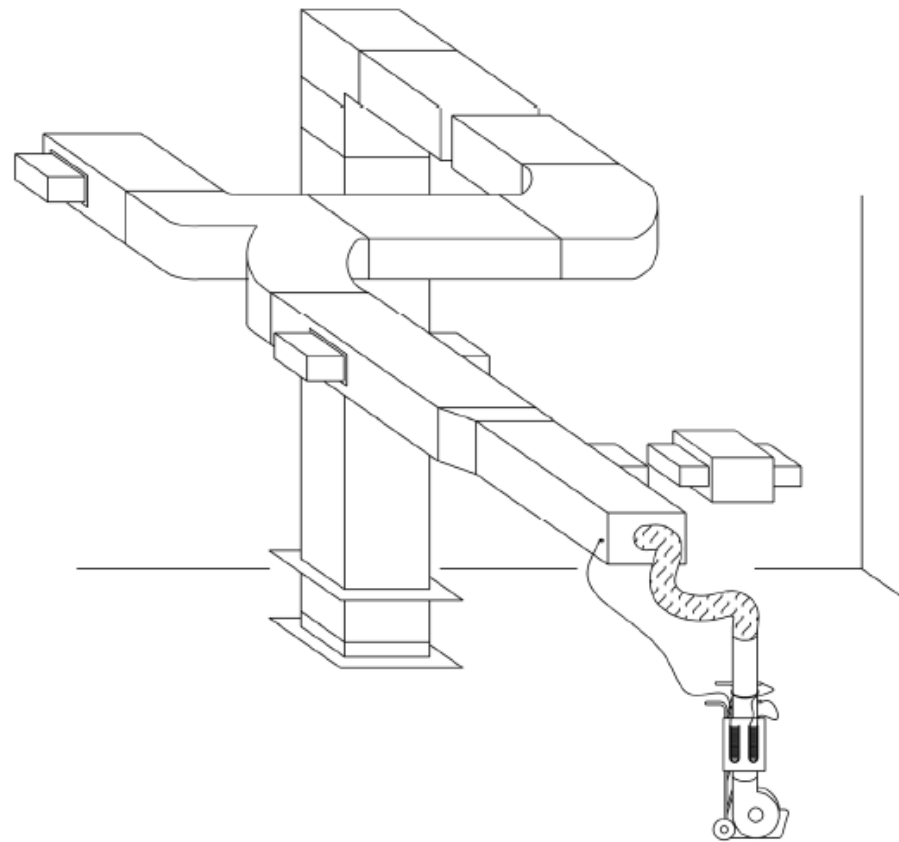

# Test Apparatus

---

- Test apparatus consists of the following:
  - Air flow measuring device (orifice tube)
  - Flow producing unit (fan)
  - Pressure indicating devices (Manometers)
  - Accessories to connect the apparatus to the system (tubing, flex hose)
  - Flow adjustment (typically a blast gate)
  - Optional item (smoke generator)



# Test Apparatus

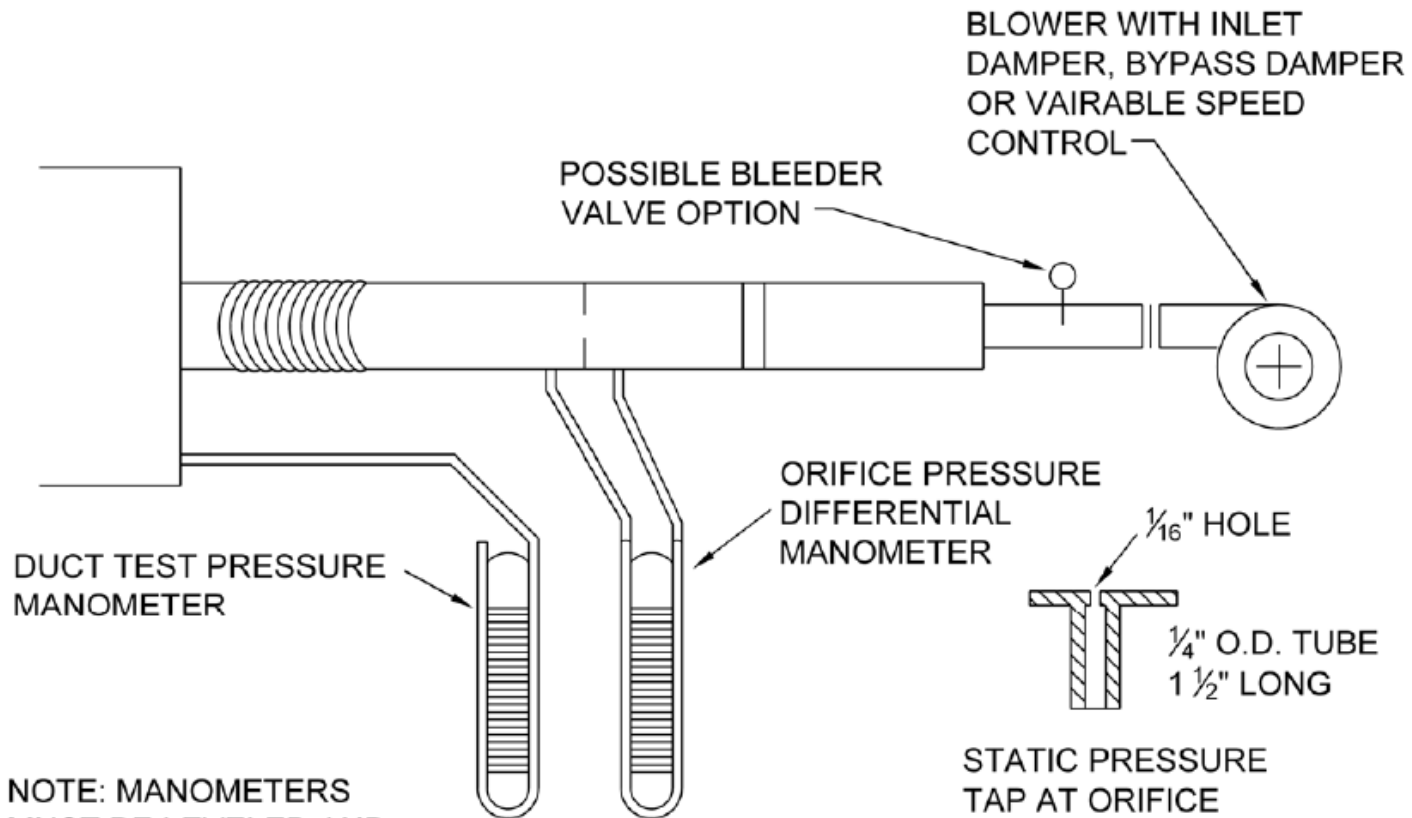

NOTE: MANOMETERS  
MUST BE LEVELED AND  
ADJUSTED TO ZERO  
BEFORE LINE

TYPICAL LAYOUT





# Test Apparatus

BEFORE LINE  
PRESSURE IS IMPOSED.

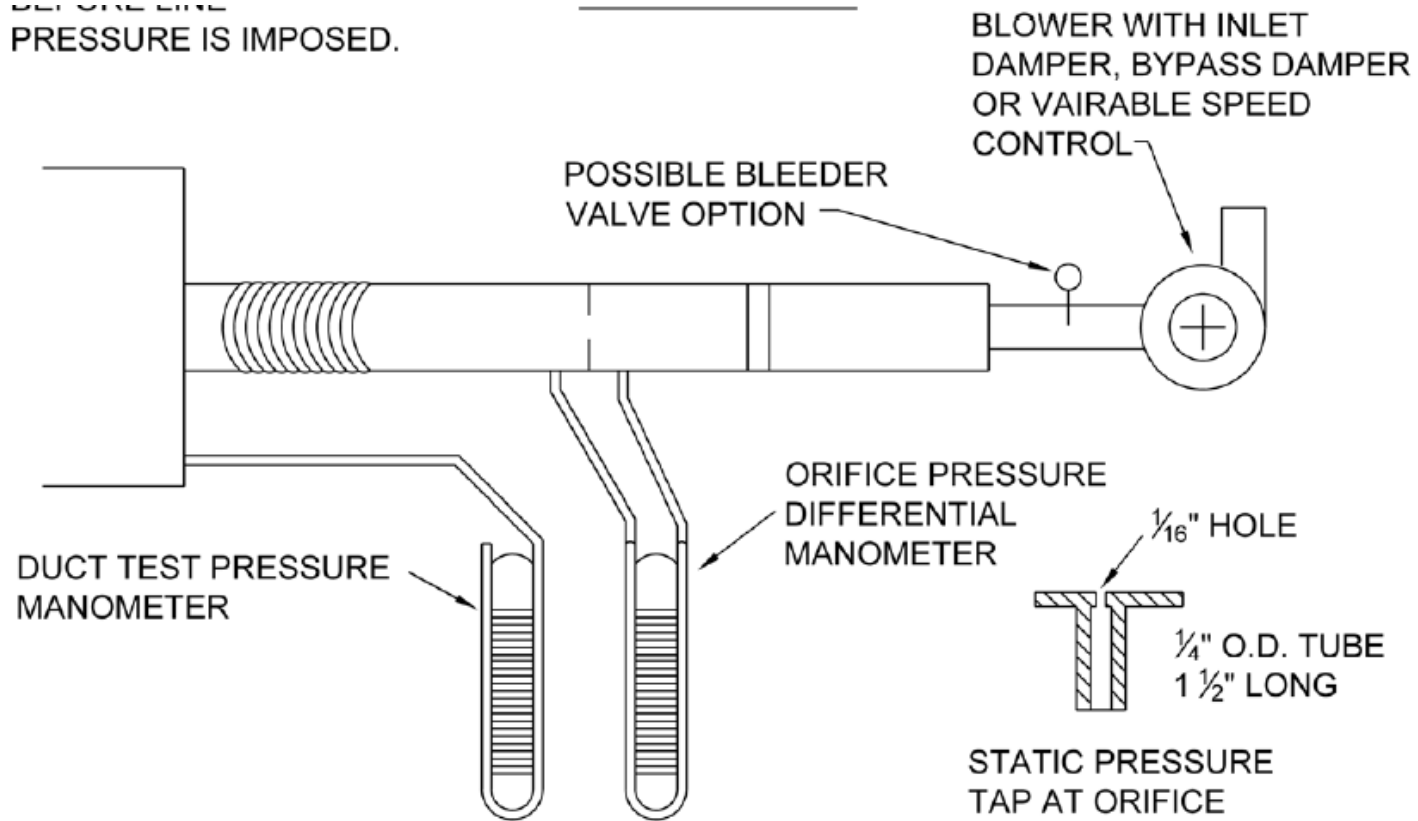

OPTIONAL LAYOUT



# Test Apparatus

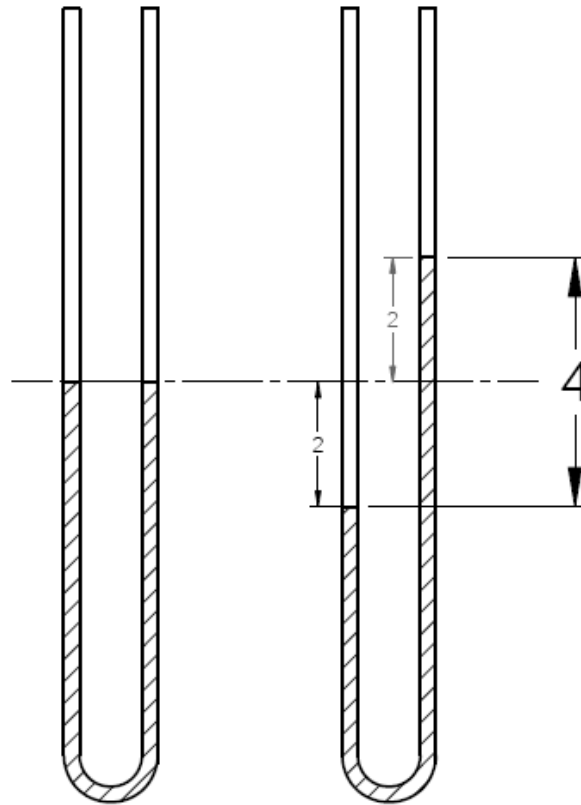

Utube Manometer at 0 in. w.g.  
The fluid is level

Utube Manometer at 4 in. w.g.  
As measured from the top of  
each column of fluid (not  
from 0)



# Test Apparatus

---

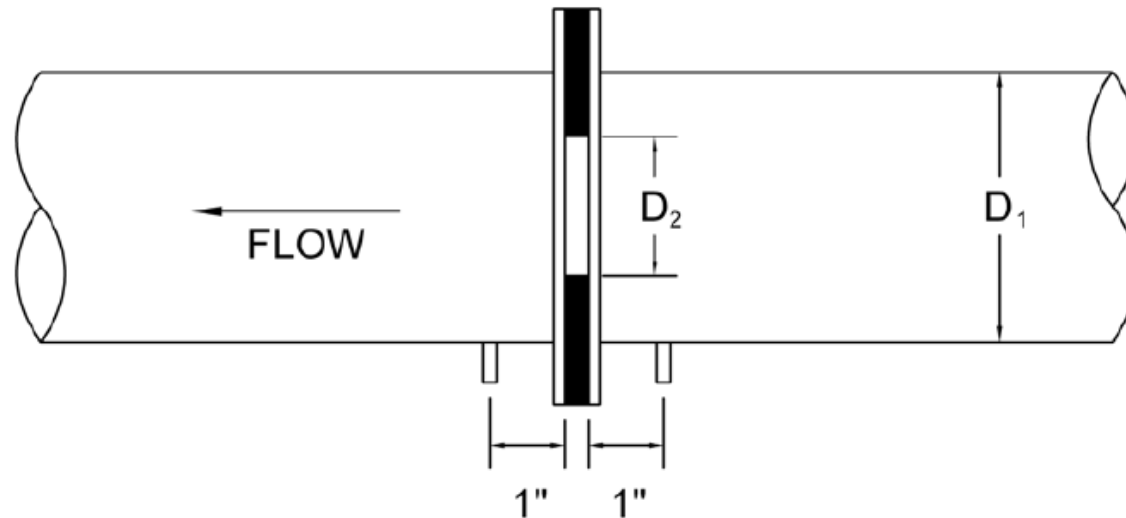

LOCATION OF FLANGE TAPS

USE  $\frac{3}{32}$ " OR  $\frac{1}{8}$ " STEEL SQUARE EDGE ORIFICE PLATE



# Test Apparatus

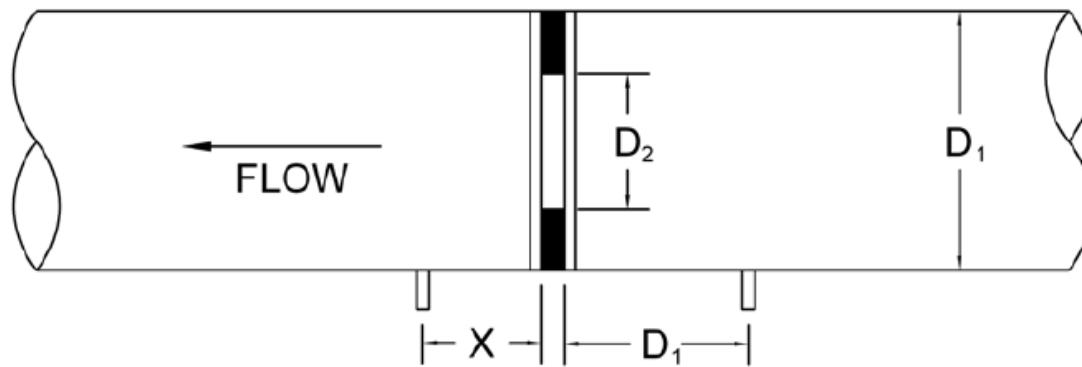

LOCATION OF VENA CONTRACTA TAPS  
USE  $\frac{3}{32}$ " OR  $\frac{1}{8}$ " STEEL SQUARE EDGE ORIFICE PLATE

$\frac{D_2}{D_1}$	X
0.2	$0.74 D_1$
0.3	$0.71 D_1$
0.4	$0.66 D_1$
0.5	$0.60 D_1$
0.6	$0.53 D_1$
0.7	$0.45 D_1$
0.8	$0.36 D_1$



# Test Procedures

---

1. Select a section of duct to be tested (see note 4).
2. Select a test pressure (never in excess of the construction pressure class). Ideally the operating pressure.
3. Calculate the allowable leakage using leakage factors for the duct surface area.



# Test Procedures

---

4. Select blower and orifice suitable for the test air flow requirements (may need to divide the test section into subsections)
5. Connect the blower and flowmeter to the duct section
6. Provide temporary seals at all openings



# Test Procedures

---

7. Start the blower at a low airflow capacity. Increase capacity until test pressure is reached.
8. Adjust as necessary until the proper pressure is reached at steady state conditions.



# Test Procedures

---

9. Record the airflow (pressure across the orifice) at steady state.
10. Compare leakage rate as tested to allowable leakage rate.





# Specifications

---

No leakage tests are required by the SMACNA duct construction standards or by this leakage test manual. When the designer has only required leakage tests to be conducted in accordance with the SMACNA *HVAC Air Duct Leakage Test Manual* for verification that the leakage classifications in Table 1 have been met (and has given no other criteria and scope), he is deemed to have not fulfilled the responsibilities outlined in section 2.1 for providing a clear scope of work. When duct construction pressure classes are not identified in the contract drawings and the amount of leakage testing is not set forth in the contract documents, any implied obligation of the installer to fulfill the responsibilities under section 2.2 in regard to leakage are deemed to be waived by defective specification.



- Figure 4-1
- Duct Leakage Classification
- Note that leakage class and allowable leakage @ 1 in. w.g. are equal

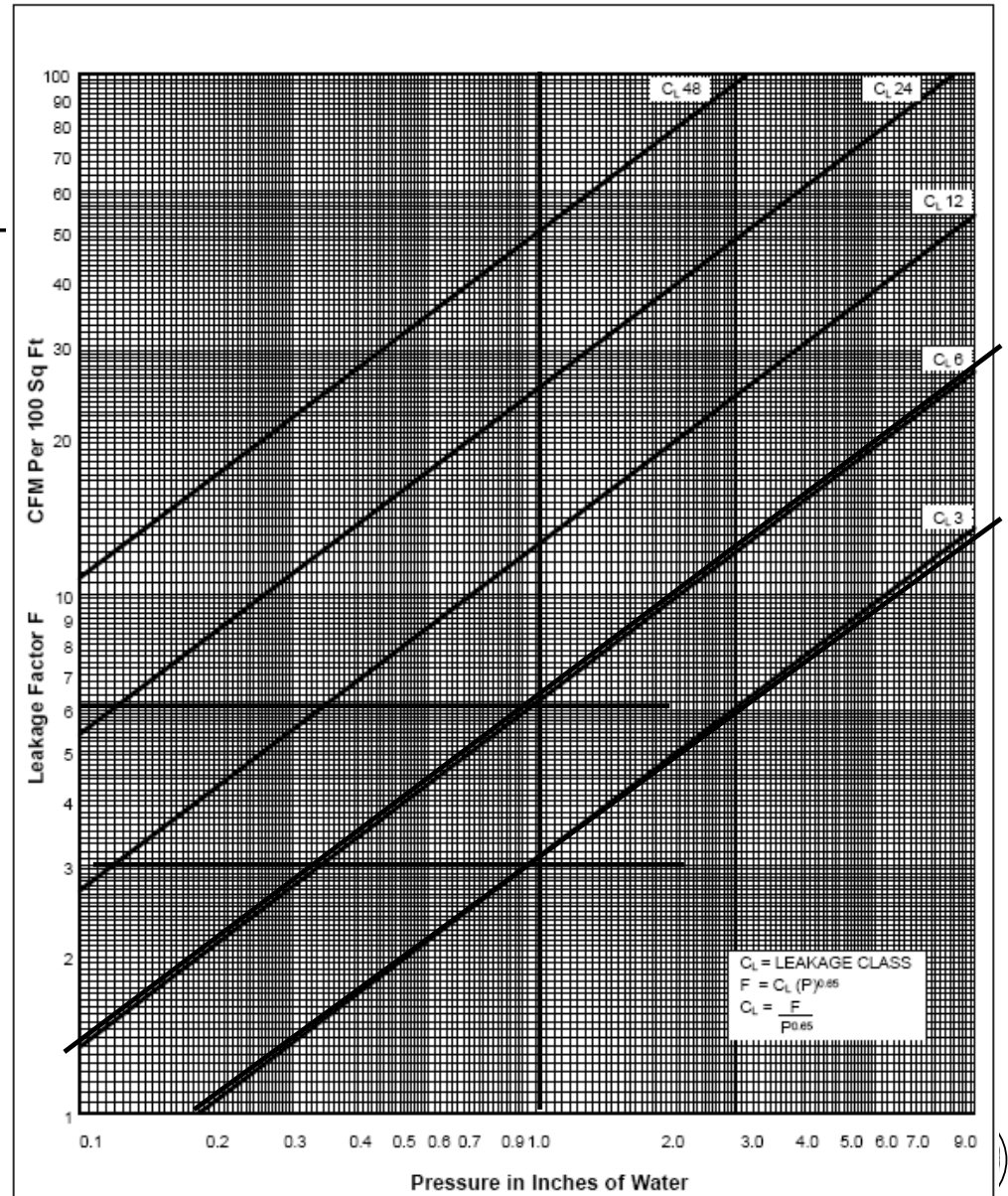

# Figure 4-1

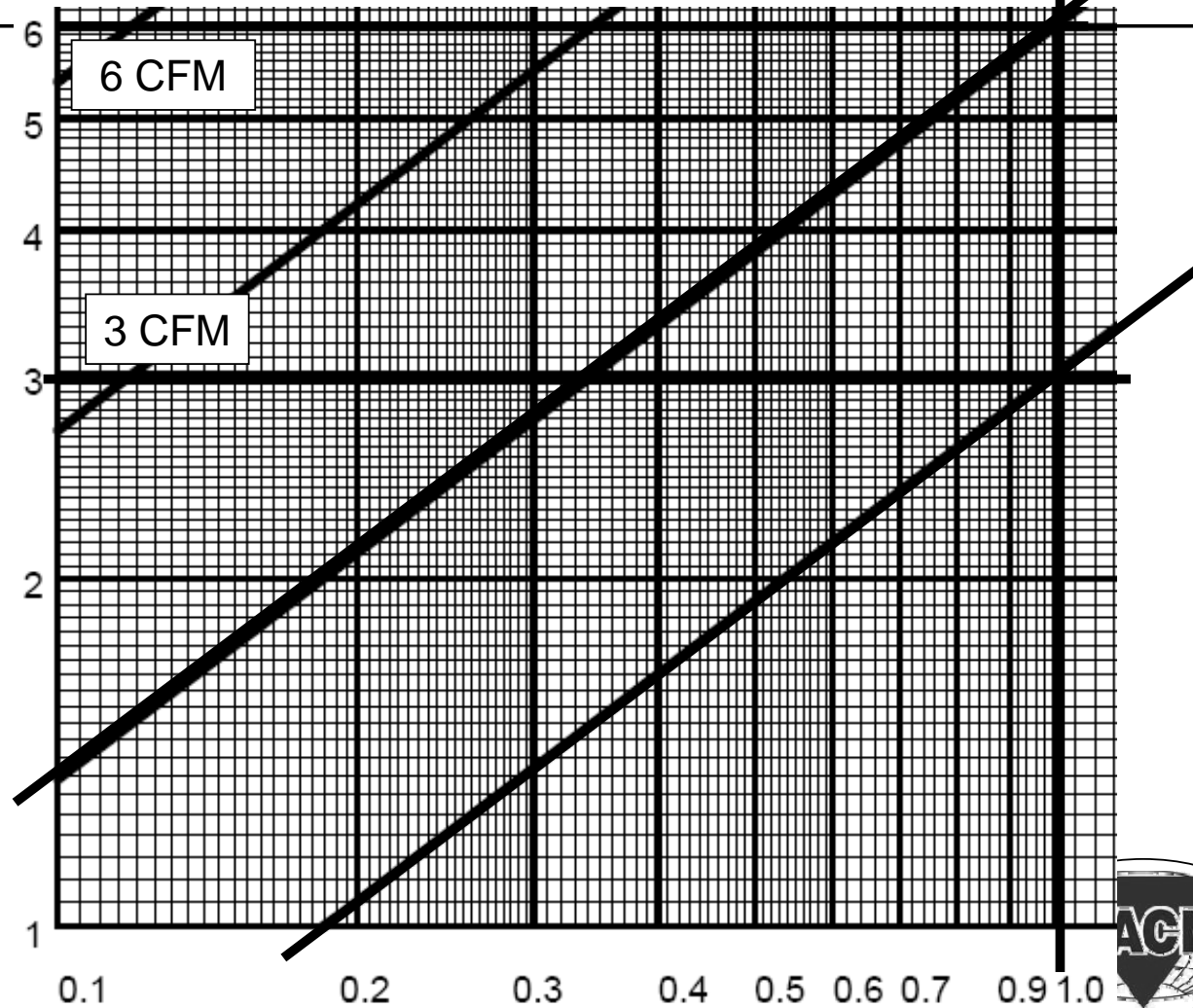

# Figure 4-1

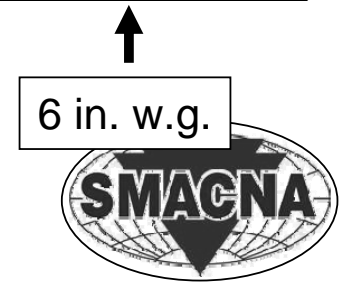
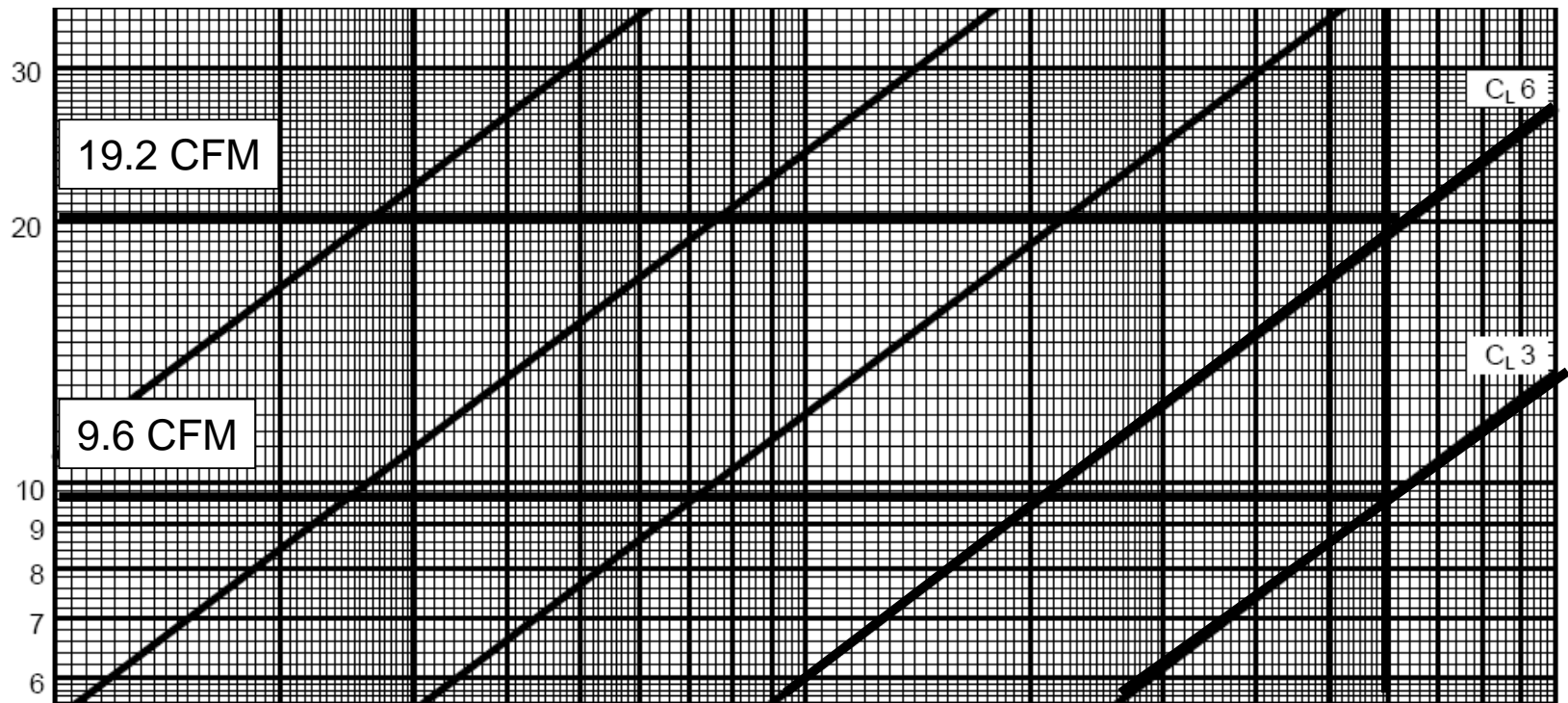

# Equation 5-1

- ❑ Used to estimate the air flowing through the orifice tube.
- ❑ Tube should be calibrated (most common) unless tube constructed to ASME standards (rare)

5.14 Airflow across a sharp edge orifice with standard air density of .075 lb/ft<sup>3</sup> is calculated from

$$Q = 21.8K(D_2)^2 \sqrt{\Delta P}$$

**Equation 5-1**

Where

Q = air volume, cfm

K = coefficient of airflow from Table 5-1 or Appendix J

D = orifice diameter, inches (D<sub>2</sub>)

DP= Pressure drop across orifice, inches wg

D <sub>2</sub> /D <sub>1</sub>	0.70	0.60	0.50	0.40	0.30
A <sub>2</sub> /A <sub>1</sub>	0.490	0.36	0.250	0.160	0.090
K	0.699	0.650	0.623	0.608	0.600
K <sub>p</sub>	0.52	0.63	0.73	0.82	0.88

**Table 5-1 Orifice Coefficients**

# Figure 5-3

- Use this just like Figure 4-1
- Tabular form typically included by tube manufacturer

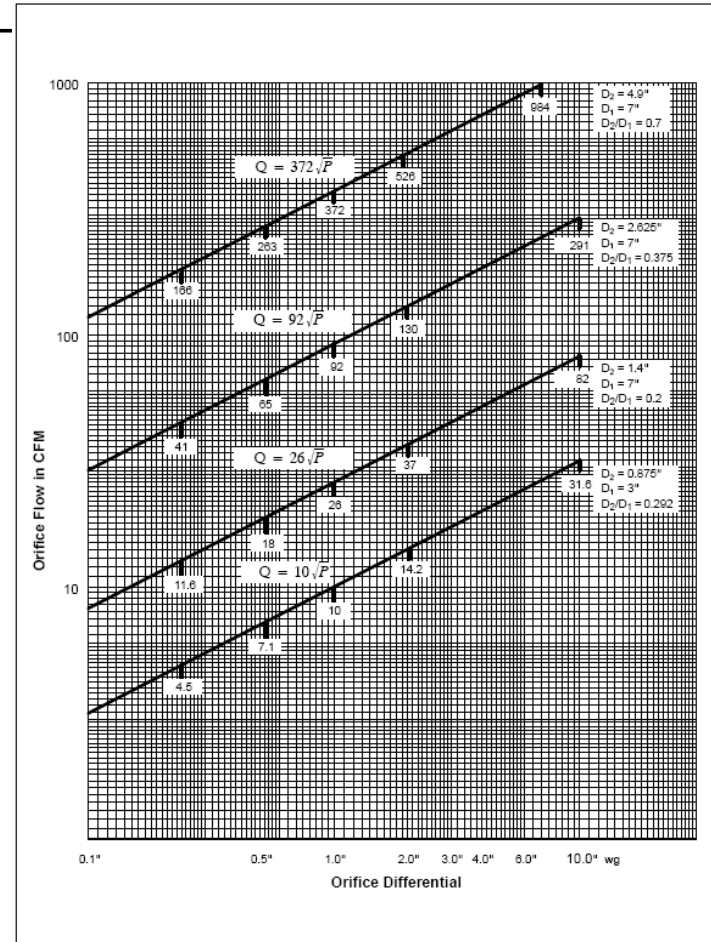

FIGURE 5-3 TYPICAL ORIFICE FLOW CURVES



# Tabular Form of Figure 5-3

---

$\Delta P$ in. wg	Orifice Size			$\Delta P$ in. wg	Orifice Size			$\Delta P$ in. wg	Orifice Size		
	1.4"	2.625"	4.90"		1.4"	2.625"	4.90"		1.4"	2.625"	4.90"
0.02			57.1	1.22	28.7	101.4	410.3	4.10	52.3	185.3	746
0.04		18.7	78.8	1.24	28.9	102.3	413.6	4.20	52.9	187.5	755
0.06		22.8	95.3	1.26	29.2	103.1	416.9	4.30	53.5	189.7	763
0.08		26.2	109.2	1.28	29.4	103.9	420.1	4.40	54.1	191.9	772
0.10		29.3	121.5	1.30	29.6	104.7	423.4	4.50	54.7	194.0	781
0.12		32.1	132.6	1.32	29.8	105.5	426.5	4.60	55.3	196.2	789
0.14		34.6	142.8	1.34	30.1	106.3	429.7	4.70	55.9	198.3	797
0.16		37.0	152.3	1.36	30.3	107.1	432.9	4.80	56.5	200.4	806
0.18		39.2	161.2	1.38	30.5	107.9	436.0	4.90	57.1	202.4	814
0.20		41.3	169.6	1.40	30.7	108.6	439.1	5.00	57.6	204.4	822
0.22		43.3	177.6	1.42	30.9	109.4	442.2	5.10	58.2	206.5	830
0.24		45.2	185.2	1.44	31.2	110.2	445.2	5.20	58.8	208.5	838
0.26		47.0	192.6	1.46	31.4	110.9	448.3	5.30	59.3	210.4	846
0.28		48.8	199.6	1.48	31.6	111.7	451.3	5.40	59.9	212.4	854
0.30		50.5	206.5	1.50	31.8	112.4	454.3	5.50	60.4	214.3	862



# EXAMPLE

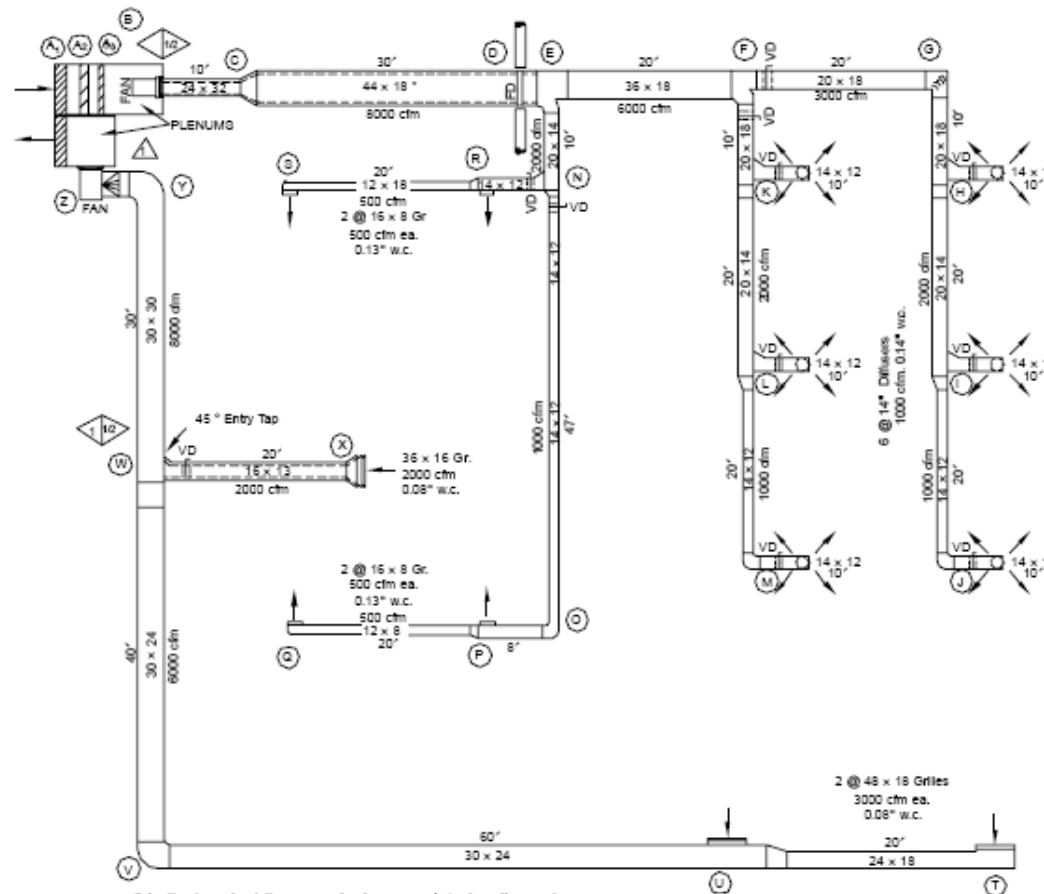



# EXAMPLE

---

- ❑ The sections to be tested are already determined.
- ❑ Total Fan CFM 24,000
- ❑ The test pressure is 6 in. w.g.
- ❑ Verify this is less than or equal to the construction pressure class.
- ❑ Calculate the allowable leakage



# EXAMPLE

---

## AIR DUCT LEAKAGE TEST SUMMARY

AIR SYSTEM \_\_\_\_\_  
 FAN CFM (Q) \_\_\_\_\_

LEAKAGE CLASS \_\_\_\_\_  
 SPECIFIED TEST PRESSURE (P<sub>t</sub>) \_\_\_\_\_  
 DUCT CONSTRUCTION PRESSURE CLASS (P<sub>c</sub>) \_\_\_\_\_

DESIGN DATA				FIELD TEST DATA RECORD							
SUBJECT DUCT	SURFAC AREA IN FT <sup>2</sup>	ALLOWABLE LEAKAGE		DIAMETER		PRESSURE " W.G.		DATE	PERFORMED BY	WITNESSED BY	ACTUAL CFM
		FACTOR CFM/100 FT <sup>2</sup>	CFM (TEST SECTION)	ORIFICE	TUBE	DUCT	ACROSS ORIFICE				
TOTAL SYSTEM				****	***	**	*****	****	****	****	
TEST SETION(S)											



# EXAMPLE

---

## AIR DUCT LEAKAGE TEST SUMMARY

AIR SYSTEM HVAC-2

FAN CFM (Q) 24,000

LEAKAGE CLASS 3

SPECIFIED TEST PRESSURE (P<sub>t</sub>) 6"

DUCT CONSTRUCTION PRESSURE CLASS (P<sub>c</sub>) 6"

- ❑ Add the information to the form
  
- ❑ Next, Calculate the allowable leakage
  - Calculate the allowable leakage per 100 ft<sup>2</sup> of duct surface area, or leakage rate (F) using the leakage class C<sub>L</sub> and the test pressure (P)
  - Calculate the surface area of the duct
  - Using the leakage rate determine the allowable leakage.



# EXAMPLE

□ Figure 4-1

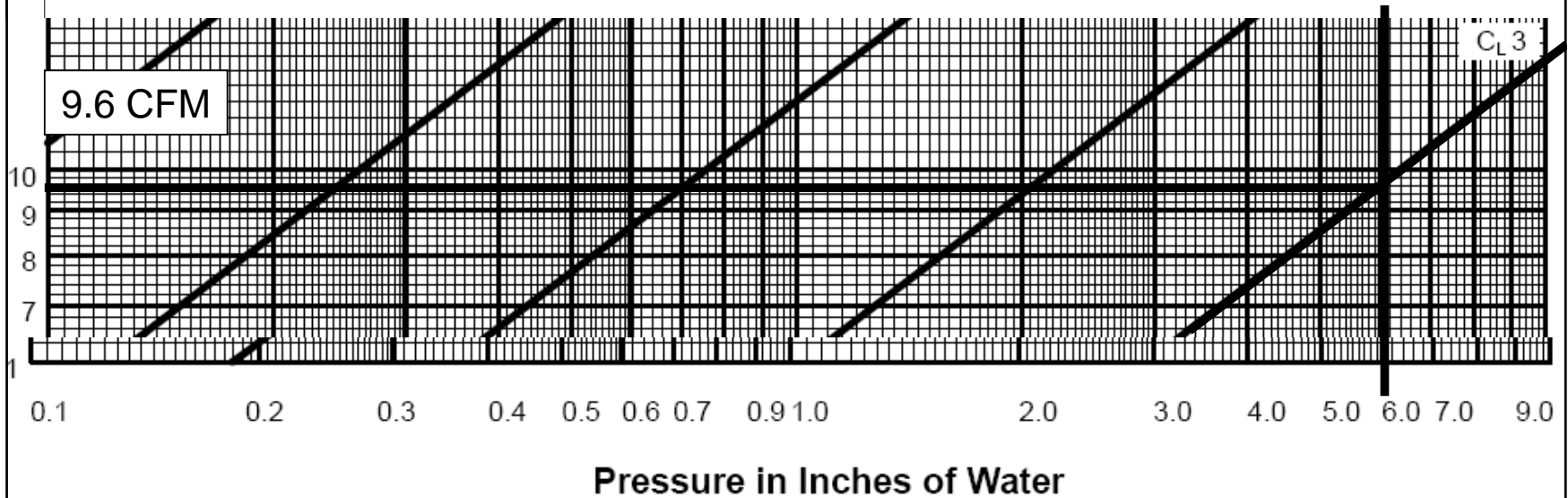

6 in. w.g.



# EXAMPLE

---

- $F = C_L P^{0.65}$
- $F = 3 \times 6^{0.65}$
- $F = 9.6 \text{ cfm}/100 \text{ ft}^2$
  
- If your surface area is  $840 \text{ ft}^2$  the allowable leakage is  $81 \text{ cfm}$

$$840 \text{ ft}^2 \times \frac{9.6 \text{ cfm}}{100 \text{ ft}^2} = 80.64 \text{ cfm}$$

- Put the information on the form



# EXAMPLE

DESIGN DATA			
SUBJECT DUCT	SURFACE-AREA IN FT <sup>2</sup>	ALLOWABLE LEAKAGE	
		FACTOR CFM/100 FT <sup>2</sup>	CFM (TEST SECTION)
TOTAL SYSTEM	9600		
TEST SETION(S)			
<i>RISERS</i>	840	9.6	81
<i>3rd FL. MAIN</i>	560	9.6	54
<i>NORTH BRANCH</i>	410	9.6	39
<i>EAST BRANCH</i>	480	9.6	46
<i>TOTAL</i>	2290		220
<i>(SEGMENTS TESTED)</i>			

- Next note the information on the test apparatus used such as orifice dimensions. Make sure the fan/tube combination can measure the leakage rates at the test pressure



# EXAMPLE

DESIGN DATA					
SUBJECT DUCT	SURFACE-AREA IN FT <sup>2</sup>	ALLOWABLE LEAKAGE		DIAMETER	
		FACTOR CFM/100 FT <sup>2</sup>	CFM (TEST SECTION)	ORIFICE	TUBE
TOTAL SYSTEM	9600			****	***
TEST SETION(S)					
<i>RISERS</i>	840	9.6	81	2.625"	7"
<i>3rd FL. MAIN</i>	560	9.6	54	1.4"	7"
<i>NORTH BRANCH</i>	410	9.6	39	1.4"	7"
<i>EAST BRANCH</i>	480	9.6	46	1.4"	7"
<i>TOTAL</i>	2290		220		
<i>(SEGMENTS TESTED)</i>					



# EXAMPLE

---

- Connect the test apparatus to the system and prepare to test.
  - Make sure all openings are sealed.
  - Make sure U-tubes are connected properly and any valves are open.
  - The fluid should be level before the fan is turned on
  - Start with the damper/blast gate closed
  - Turn on the fan





# EXAMPLE

---

- Bring the system to the test pressure and steady state
  - Slowly open the damper
  - Give the system a minute to reach steady state
    - The time required depends on the setup used if the test is near the equipments limit this can take a couple of minutes
- Note the pressure across the orifice
  - Add this information to the form



# EXAMPLE

DESIGN DATA				FIELD TEST DATA RECORD							
SUBJECT DUCT	SURFACE-AREA IN FT <sup>2</sup>	ALLOWABLE LEAKAGE		DIAMETER		PRESSURE " W.G.		DATE	PERFORMED BY	WITNESSED BY	ACTUAL CFM
		FACTOR CFM/100 FT <sup>2</sup>	CFM (TEST SECTION)	ORIFICE	TUBE	DUCT	ACROSS ORIFICE				
TOTAL SYSTEM	9600			****	***	**	*****	****	****	****	
TEST SETION(S)											
<i>RISERS</i>	<i>840</i>	<i>9.6</i>	<i>81</i>	<i>2.625"</i>	<i>7"</i>	<i>6</i>	<i>0.6</i>	<i>3.7.85</i>	<i>JRL</i>	<i>UNG</i>	<i>71</i>
<i>3rd FL. MAIN</i>	<i>560</i>	<i>9.6</i>	<i>54</i>	<i>1.4"</i>	<i>7"</i>	<i>6</i>	<i>3.2</i>	<i>3.13.85</i>	<i>JRL</i>	<i>UNG</i>	<i>46</i>
<i>NORTH BRANCH</i>	<i>410</i>	<i>9.6</i>	<i>39</i>	<i>1.4"</i>	<i>7"</i>	<i>6</i>	<i>3.5</i>	<i>4.16.85</i>	<i>ABT</i>	<i>UNG</i>	<i>48</i>
<i>EAST BRANCH</i>	<i>480</i>	<i>9.6</i>	<i>46</i>	<i>1.4"</i>	<i>7"</i>	<i>6</i>	<i>1.8</i>	<i>4.19.85</i>	<i>ABT</i>	<i>UNG</i>	<i>35</i>

- ❑ Add other information such as date/tested by/witnessed by
- ❑ Calculate/Lookup actual CFM add it to the form



# EXAMPLE

- Orifice tube diameter = 7 in.
- Orifice diameter = 2.625 in.
- Pressure drop across the orifice = 0.6 in. w.g.
- Figure 5-3

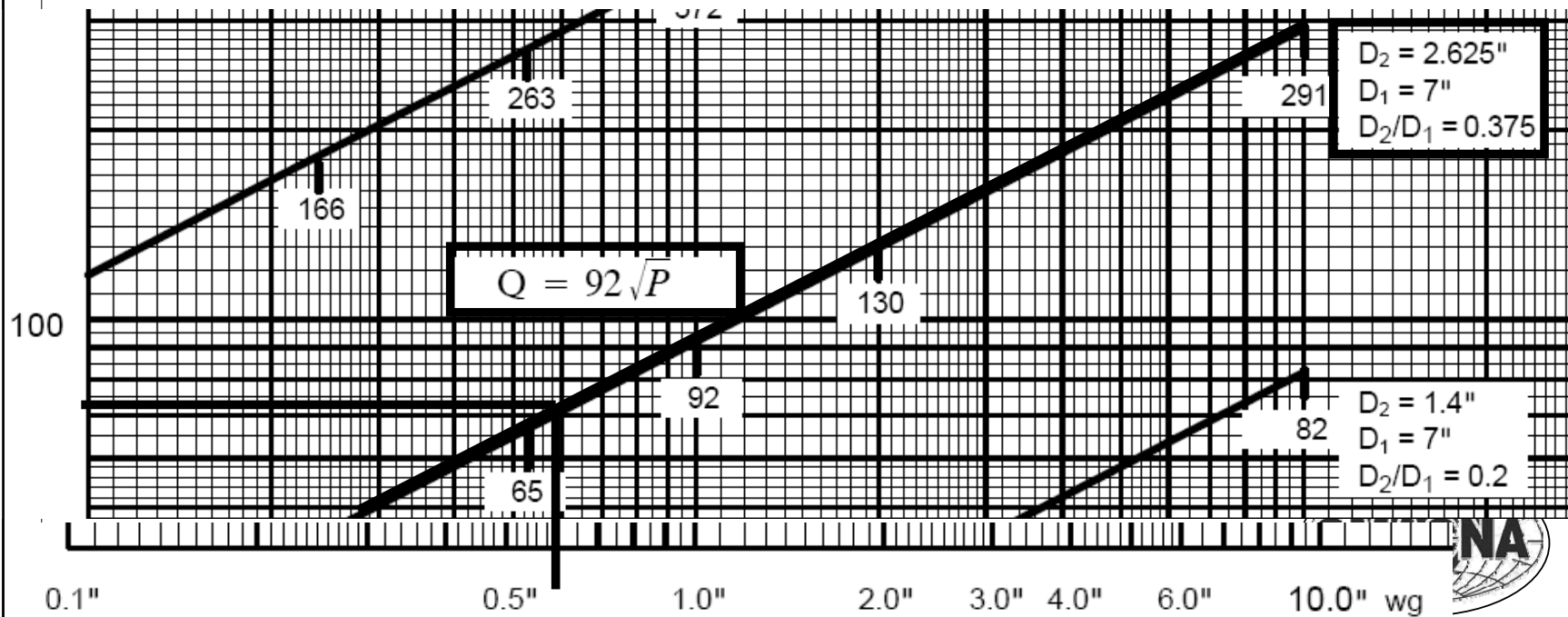

# EXAMPLE

- Orifice tube diameter = 7 in.
- Orifice diameter = 2.625 in.
- Table 5-2

$\Delta P$ in. wg	Orifice Size		
	1.4"	2.625"	4.90"
0.54	19.2	67.6	275.0
0.56	19.5	68.9	280.0
0.58	19.9	70.1	284.8
0.60	20.2	71.3	289.6
0.62	20.6	72.4	294.3
0.64	20.9	73.6	298.9
0.66	21.2	74.7	303.4



# EXAMPLE

## AIR DUCT LEAKAGE TEST SUMMARY

AIR SYSTEM HVAC-2  
 FAN CFM (Q) 24,000

LEAKAGE CLASS 3  
 SPECIFIED TEST PRESSURE (P<sub>t</sub>) 6"  
 DUCT CONSTRUCTION PRESSURE CLASS (P<sub>c</sub>) 6"

DESIGN DATA				FIELD TEST DATA RECORD							
SUBJECT DUCT	SURFACE-AREA IN FT <sup>2</sup>	ALLOWABLE LEAKAGE		DIAMETER		PRESSURE " W.G		DATE	PERFORMED BY	WITNESSED BY	ACTUAL CFM
		FACTOR CFM/100 FT <sup>2</sup>	CFM (TEST SECTION)	ORIFICE	TUBE	DUCT	ACROSS ORIFICE				
TOTAL SYSTEM	9600			****	***	**	*****	****	****	****	
TEST SECTION(S)											
RISERS	840	9.6	81	2.625"	7"	6	0.6	3.7.85	JRL	UNG	71
3rd FL. MAIN	560	9.6	54	1.4"	7"	6	3.2	3.13.85	JRL	UNG	46
NORTH BRANCH	410	9.6	39	1.4"	7"	6	3.5	4.16.85	ABT	UNG	48
EAST BRANCH	480	9.6	46	1.4"	7"	6	1.8	4.19.85	ABT	UNG	35
TOTAL	2290		220								200
(SEGMENTS TESTED)											



# Comments/Discussion

---

- The fan is wide open but I can't get the system up to pressure
  - Check for openings
  - Make sure U-tube valves are open
- I can't get a pressure across the orifice
  - Check U-tube valves
  - Check tubing (proper connections)



# Comments/Discussion

---

- ❑ Does SMACNA “recognize” leakage class 4?
  - You can assign any leakage class you want. You must understand what you are really asking for. SMACNA’s HVAC AIR DUCT LEAKAGE TEST MANUAL provides leakage rates based on testing ducts constructed to the SMACNA HVAC DCS.
  
- ❑ Does the SMACNA test work on equipment or casings?
  - SMACNA has not tested those items to see if the method or the predicted leakage rates apply



# Comments / Discussion

---

- When is sealant not required by SMACNA?
  - CAV systems at or below 2 in. wg.
  - Fully welded duct systems
  
- Leakage rates should not be an arbitrary value (such as 1% of system airflow)
  - These values can result in unobtainable goals





# Leakage as % to Air Flow

Leakage Class	System Airflow		Static Pressure in. wg (Pa)					
	cfm/ft <sup>2</sup>	l/s per m <sup>2</sup>	½ (125)	1 (250)	2 (500)	3 (750)	4 (1000)	6 (1500)
48	2	10	15	24	38			
	2.5	12.7	12	19	30			
	3	15	10	16	25			
	4	20	7.7	12	19			
	5	25	6.1	9.6	15			
24	2	10	7.7	12	19			
	2.5	12.7	6.1	9.6	15			
	3	15	5.1	8.0	13			
	4	20	3.8	6.0	9.4			
	5	25	3.1	4.8	7.5			
12	2	10	3.8	6	9.4	12		
	2.5	12.7	3.1	4.8	7.5	9.8		
	3	15	2.6	4.0	6.3	8.2		
	4	20	1.9	3.0	4.7	6.1		
	5	25	1.5	2.4	3.8	4.9		
6	2	10	1.9	3	4.7	6.1	7.4	9.6
	2.5	12.7	1.5	2.4	3.8	4.9	5.9	7.7
	3	15	1.3	2.0	3.1	4.1	4.9	6.4
	4	20	1.0	1.5	2.4	3.1	3.7	4.8
	5	25	.8	1.2	1.9	2.4	3.0	3.8
3	2	10	1.0	1.5	2.4	3.1	3.7	4.8
	2.5	12.7	.8	1.2	1.9	2.4	3.0	3.8
	3	15	.6	1.0	1.6	2.0	2.5	3.2
	4	20	.5	.8	1.3	1.6	2.0	2.6
	5	25	.4	.6	.9	1.2	1.5	1.9



# Leakage as % to Air Flow

---

Leakage Class	System Airflow		Static Pressure in. wg (Pa)					
	cfm/ft <sup>2</sup>	l/s per m <sup>2</sup>	½ (125)	1 (250)	2 (500)	3 (750)	4 (1000)	6 (1500)
6	2	10	1.9	3	4.7	6.1	7.4	9.6
	2.5	12.7	1.5	2.4	3.8	4.9	5.9	7.7
	3	15	1.3	2.0	3.1	4.1	4.9	6.4
	4	20	1.0	1.5	2.4	3.1	3.7	4.8
	5	25	.8	1.2	1.9	2.4	3.0	3.8
3	2	10	1.0	1.5	2.4	3.1	3.7	4.8
	2.5	12.7	.8	1.2	1.9	2.4	3.0	3.8
	3	15	.6	1.0	1.6	2.0	2.5	3.2
	4	20	.5	.8	1.3	1.6	2.0	2.6
	5	25	.4	.6	.9	1.2	1.5	1.9



# Thank You

---

Questions  
&  
Answers

