

HVAC DUCT CONSTRUCTION STANDARDS

April, 2010

Presented by:

Mark Terzigni
Project Manager
Technical Services

HVAC DUCT CONSTRUCTION STANDARDS METAL AND FLEXIBLE



HVAC DUCT CONSTRUCTION STANDARDS METAL AND FLEXIBLE



ANSI/SMACNA 006-2006



SHEET METAL AND AIR CONDITIONING CONTRACTORS'
NATIONAL ASSOCIATION, INC.
www.smacna.org



Information Required for Duct Construction

1. A comprehensive duct layout indicating sizes, design airflows, pressure class, and routing of the duct system.
2. The types of fittings to be used based on the designer's calculations of fitting losses (i.e., square versus 45° entry taps, conical versus straight taps, etc.).



Information Required for Duct Construction

3. Use of turning vanes or splitter vanes.
4. Location of access doors.
5. Location and type of control and balancing dampers.
6. Location and types of diffusers.
7. Requirements for duct insulation.



Information Required for Duct Construction

8. Location and types of any fire protection device including fire dampers, smoke dampers, combination fire/smoke dampers, and ceiling dampers. Building codes require this information to be shown on the design documents submitted for building permit.



Information Required for Duct Construction

9. Details of offsets required to route ductwork around obstructions (columns, beams, etc.).



Information Required for Duct Construction

ENGINEER

Design Considerations:

CFM

Static Pressure

Duct Size

Fitting Type

Construction
Pressure Class

CONTRACTOR

Construction Considerations:

Pressure Class
(as specified)

Panel Thickness (Gage)

Panel Width/Height

Joint Type/Spacing

Intermediate
Reinforcement
Type/Spacing

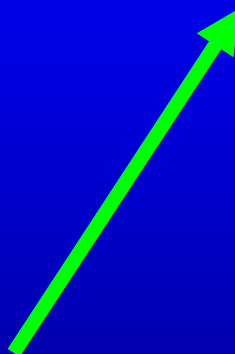

DEPENDENT VARIABLES

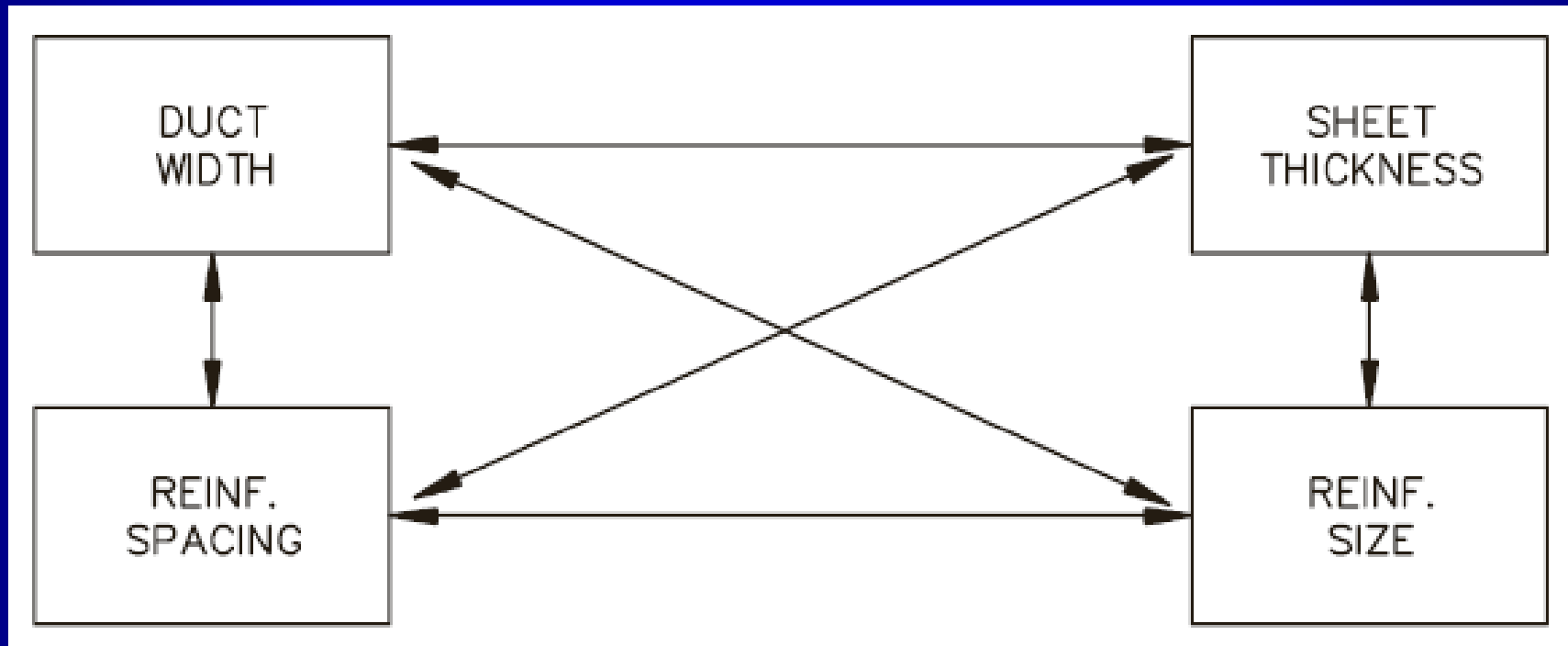

Rectangular Transverse Joints

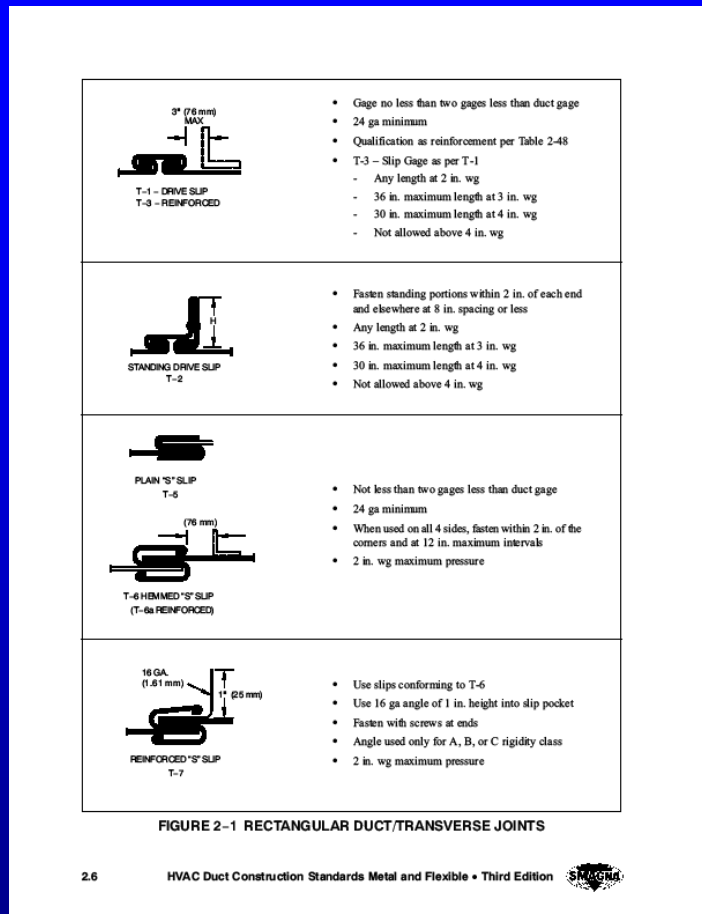

- Figure 2-1
- Pages 2.6-2.9

Rectangular

Rectangular Transverse Joints

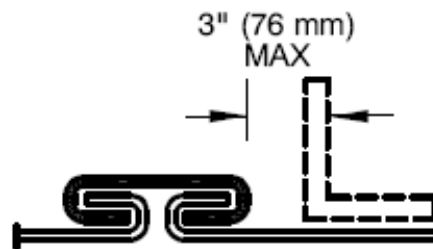

T-1 - DRIVE SLIP
T-3 - REINFORCED

- Gage no less than two gages less than duct gage
- 24 ga minimum
- Qualification as reinforcement per Table 2-48
- T-3 - Slip Gage as per T-1
 - Any length at 2 in. wg
 - 36 in. maximum length at 3 in. wg
 - 30 in. maximum length at 4 in. wg
 - Not allowed above 4 in. wg

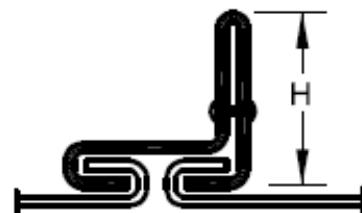

STANDING DRIVE SLIP
T-2

- Fasten standing portions within 2 in. of each end and elsewhere at 8 in. spacing or less
- Any length at 2 in. wg
- 36 in. maximum length at 3 in. wg
- 30 in. maximum length at 4 in. wg
- Not allowed above 4 in. wg

Rectangular Transverse Joints



PLAIN "S" SLIP
T-5

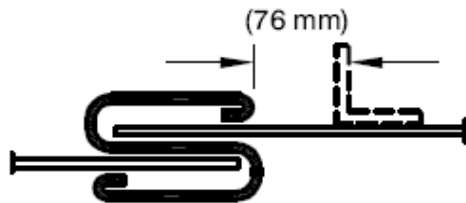

T-6 HEMMED "S" SLIP
(T-6a REINFORCED)

- Not less than two gages less than duct gage
- 24 ga minimum
- When used on all 4 sides, fasten within 2 in. of the corners and at 12 in. maximum intervals
- 2 in. wg maximum pressure

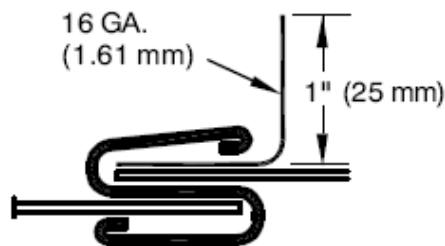

REINFORCED "S" SLIP
T-7

- Use slips conforming to T-6
- Use 16 ga angle of 1 in. height into slip pocket
- Fasten with screws at ends
- Angle used only for A, B, or C rigidity class
- 2 in. wg maximum pressure

Rectangular Transverse Joints

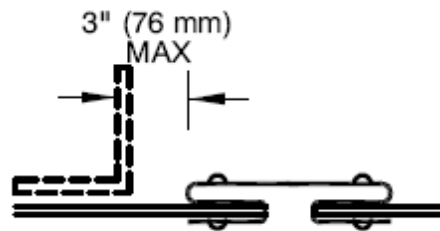

T-8 DOUBLE "S" SLIP
(T-8a REINFORCED)

- 24 ga for 30 inch width or less
- 22 ga over 30 inch width
- Fasten to each section of the duct within 2 in. from corners and at 6 in. maximum intervals
- $\frac{5}{8}$ in. minimum tabs to close corners

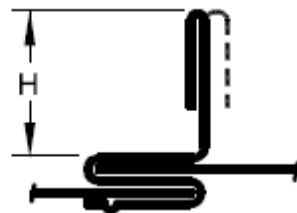

STANDING S
T-10

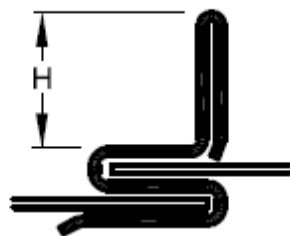

STANDING S (ALT.)
T-11

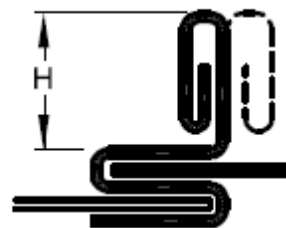

STANDING S (ALT.)
T-12

- When using S on all four sides, fasten slip to duct within 2 in. of the corner and at 12 in. maximum intervals

- Any length at 2 in. wg
- 36 in. maximum length at 3 in. wg
- 30 in. maximum length at 4 in. wg
- Not allowed above 4 in. wg

Rectangular Transverse Joints

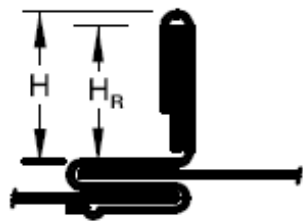

STANDING S
(BAR REINFORCED)
T-13

- Fasten as per Joint T-10
- Standing portion as per T-10 or T-11 to hold Flat Bar
- Fasten bar stock to the connector within 2 in. of the corner and at 12 in. maximum intervals

- Any length at 2 in. wg
- 36 in. maximum length at 3 in. wg
- 30 in. maximum length at 4 in. wg
- Not allowed above 4 in. wg

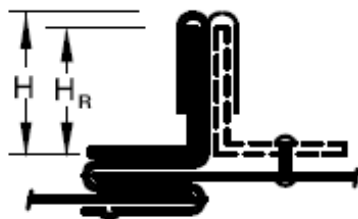

STANDING S
(ANGLE REINFORCED)
T-14

- Fasten as per Joint T-10
- Fasten angle to the connector or duct wall within 2 in. of the corner and at 12 in. maximum intervals

- Any length at 2 in. wg
- 36 in. maximum length at 3 in. wg
- 30 in. maximum length at 4 in. wg
- Not allowed above 4 in. wg

Rectangular Transverse Joints

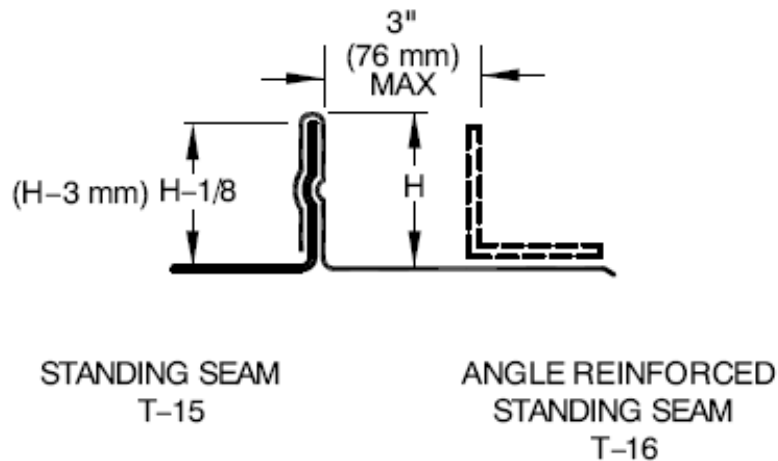

- Button punch or otherwise fasten within 2 in. of each corner and at 6 in. maximum intervals
- Seal and fold corners
- Stagger joints on adjacent sides if using standing seam on all four sides
- Hammer longitudinal seam at ends of standing seam

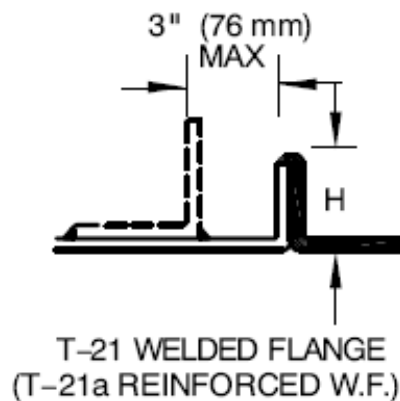

- Use $1/2$ in. minimum flange and end weld
- Flanges larger than $5/8$ in. must be spot welded, bolted, riveted or screwed to prevent separation (2 in. from ends and at 8 in. maximum intervals)
- On 24, 22 or 20 ga, brace or weld $1/4 \times 4$ in. rod in corners or provide hangers at every joint

Rectangular Transverse Joints

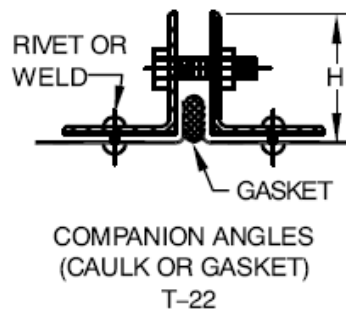

- $\frac{3}{8}$ in. minimum flange on duct
- Angles must have welded corners
- Angles must be tack welded, bolted or screwed to the duct wall at 2 in. maximum from the ends and at 12 in. maximum intervals
- Bolt Schedule:
 - $\frac{5}{16}$ minimum diameter at 6 in. maximum spacing at 4 in. wg or lower
 - $\frac{1}{8}$ in. angle requires 4 in. maximum spacing at 4 in. wg
 - 4 in. maximum spacing at higher pressures

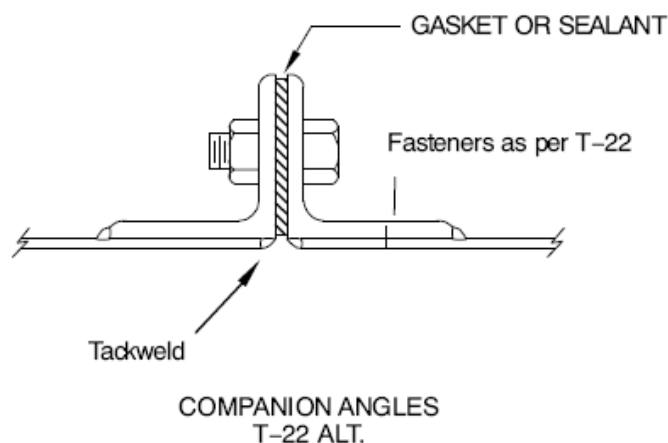

- Hold duct back $\frac{1}{8}$ in. from vertical face of the angle and tack weld to the flange along the edge of the duct
- Fasten angle to duct as per T-22
- For additional tightness place sealant between the angle and duct or seal the weld
- If the faces of the angles are flush, thick consistency sealant may be used in lieu of gasket
- Use gasket suitable for the specific service and fit it uniformly to avoid protruding into the duct

Rectangular Transverse Joints



FLANGED
(WITH GASKET)
T-24

- Assemble per Figure 2-16
- Close corners with minimum 16 ga corner pieces and $\frac{3}{8}$ in. bolts min.
- Lock flanges together with 6 in. long clips located within 6 in. of each corner
- Clips spaced at 15 in. maximum for 3 in. wg pressure class or lower
- Clips spaced at 12 in. maximum for 4, 6 and 10 in. wg
- Gasket to be located to form an effective seal

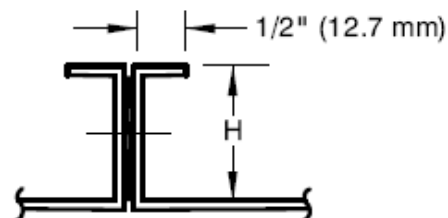

FLANGED
(WITH GASKET)
T-24A

- Bolt, rivet 1 in. maximum from ends and at 6 in. maximum intervals
- Limited to 2 in. wg pressure class
- See Figure 2-16
- Gasket to be located to form an effective seal

Rectangular Transverse Joints

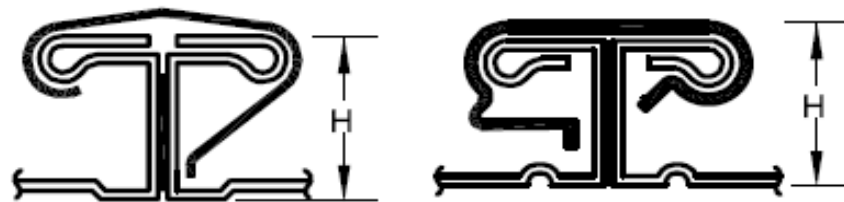

FLANGED
(WITH GASKET)
T-25a

FLANGED
(WITH GASKET)
T-25b

- Assemble per Figure 2-17
- Ratings may be adjusted with EI-rated bar stock or members from Tables 2-29 and 2-30
- Supplemental members may be attached to the duct wall on both sides of the joint
- Single members may be used if they are fastened through both mating flanges
- Gasket to be located to form an effective seal



- Consult manufacturers for ratings established by performance documented to functional criteria in Chapter 11.



Rectangular Transverse Joints

Duct Wall	26 ga		24 ga		22 ga		20 ga or Heavier	
Static Pressure	Maximum Duct Width (W) and Maximum Reinforcement Spacing (RS)							
	W	RS	W	RS	W	RS	W	RS
½ in. wg	20 in. 18 in.	10 ft N.R.	20 in.	N.R.	20 in.	N.R.	20 in.	N.R.
1 in. wg	20 in. 14 in. 12 in.	8 ft 10 ft N.R.	20 in. 14 in.	8 ft N.R.	20 in. 18 in.	10 ft N.R.	20 in.	N.R.
2 in. wg	18 in.	5 ft	18 in. 12 in.	8 ft N.R.	18 in. 14 in.	10 ft N.R.	18 in.	N.R.
3 in. wg	12 in. 10 in.	5 ft 6 ft	18 in. 10 in.	5 ft N.R.	18 in. 12 in.	5 ft N.R.	18 in. 14 in.	6 ft N.R.
4 in. wg	Not Accepted		16 in. 8 in.	5 ft N.R.	12 in. 8 in.	6 ft N.R.	12 in.	N.R.

Table 2-48 T-1 Flat Drive Accepted as Reinforcement

Figure 2-16

Corners not required up to 2 in. w.g.
Corners are required above 2 in. w.g.

BOLT OR RIVET FASTENING
1" (25 mm) MAX.
FROM THE END AND
AT 6" (150 mm)
MAX. INTERVALS

GASKET IS USED
IN THE JOINT

CONTINUOUS
CLEATS MAY
BE USED

2" WG (500 PA)
MAXIMUM FOR
THIS APPLICATION.
CORNER PIECES
ARE NOT REQUIRED.

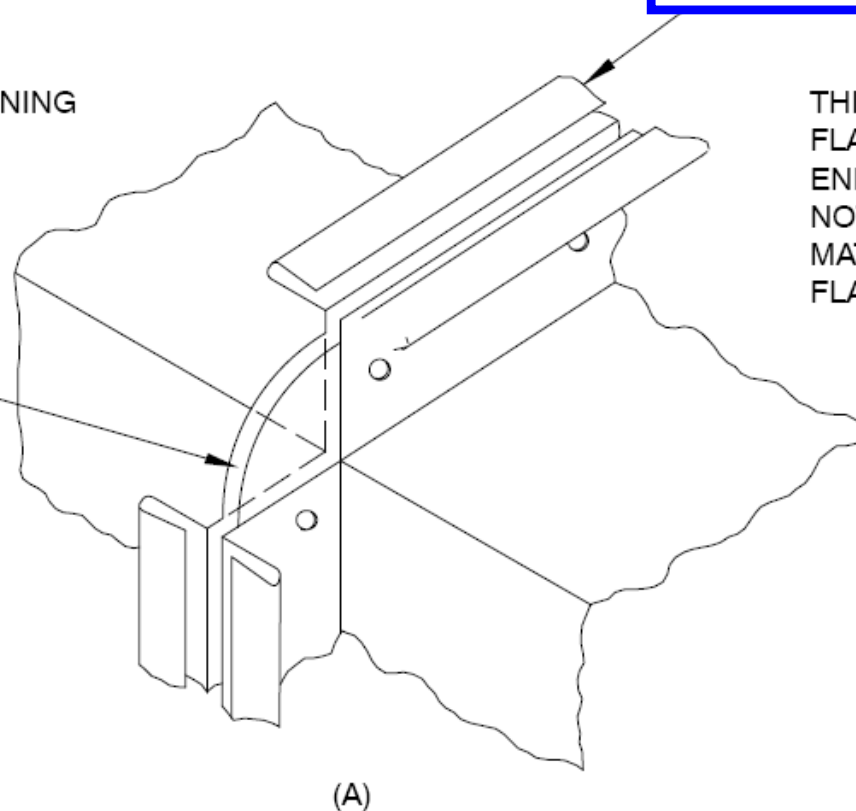

THIS ILLUSTRATION DEPICTS
FLANGES FORMED ON THE
ENDS OF DUCT. THIS DOES
NOT PRECLUDE SATISFACTORY
MATING OF DISSIMILAR
FLANGES.

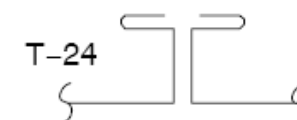
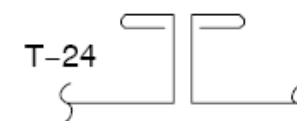
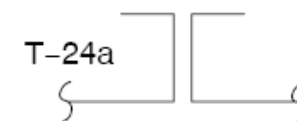

FIGURE 2-16 CORNER CLOSURES - FLANGES



Figure 2-17

CONTINUOUS
GASKET TO EFFECTIVELY
SEAL FLANGES
AND
CORNERS

SECURELY ATTACH
ADDITIONAL METAL
CLIPS ON FLANGES AT
15" (381 mm) MAXIMUM
CENTERS FOR 3" WG (750 PA)
STATIC OR LESS AND AT
12" (305 mm) MAXIMUM
CENTERS FOR HIGHER
PRESSURES. 22 GA.
(0.85 mm) MINIMUM.

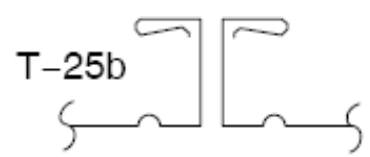
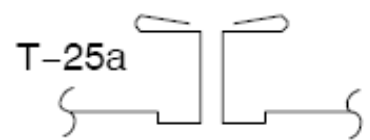
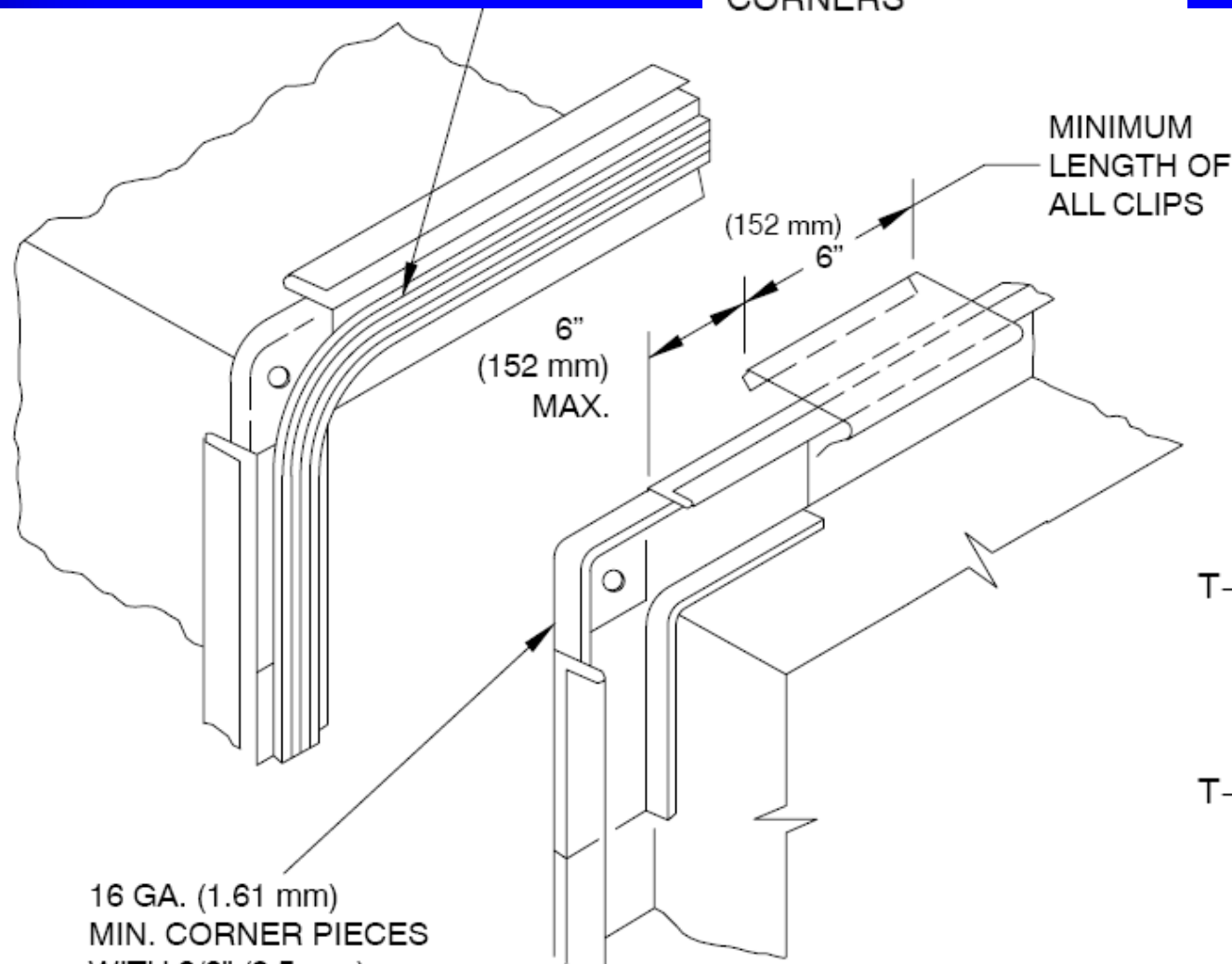

TEE FLANGES

16 GA. (1.61 mm)
MIN. CORNER PIECES
WITH 3/8" (9.5 mm)
MIN. BOLT

SCREWS MAY BE USED IN LIEU OF METAL CLIPS. INSTALL 1" (25MM) MAX. FROM
END OF CORNER PIECE AND AT 6" (152 MM) MAX. INTERVALS.

(B)

EQUIVALENT FIXATION OF JOINTS MAY BE USED. CONTINUOUS CLEATS MAY BE
USED.

Longitudinal Seams

- Figure 2-17
- Page 2.10





 <p>L-1 ALSO SEAL THIS POCKET AT ENDS WHEN SEALING SEAMS PITTSBURGH LOCK</p>	<ul style="list-style-type: none"> • Pocket depth from ¼ in. to ⅝ in. • Use on straight duct and fittings • To ±10 in. wg
 <p>L-2 BUTTON PUNCH SNAP LOCK</p>	<ul style="list-style-type: none"> • ⅝ in. pocket depth for 20, 22, and 24 ga • ½ in. pocket depth for 24 and 26 ga • To ±4 in. wg • Screws must be added at the ends of all duct of 4 in. wg and at the ends of 3 in. wg when the duct is over 48 in. width
 <p>L-3 GROOVED SEAM ALSO CALLED FLAT LOCK AND PIPE LOCK</p>	<ul style="list-style-type: none"> • To ±10 in. wg
 <p>SEE FIG. 2-7 ALSO L-4 STANDING SEAM</p>	<ul style="list-style-type: none"> • To ±10 in. wg • 1 in. seam up to duct width of 42 in. • 1 ½ in. seam for larger ducts • May be used on duct interiors • Fasten at 2 in. maximum from ends and at 8 in. maximum intervals
 <p>L-5 SINGLE CORNER SEAM</p>	<ul style="list-style-type: none"> • To ±10 in. wg • Fasten as per L-4
 <p>FLANGED (WITH GASKET) T-25a</p> <p>FLANGED (WITH GASKET) T-25b</p>	<ul style="list-style-type: none"> • Assemble per Figure 2-17 • Ratings may be adjusted with EI-rated bar stock or members from Tables 2-29 and 2-30 • Supplemental members may be attached to the duct wall on both sides of the joint • Single members may be used if they are fastened through both mating flanges • Gasket to be located to form an effective seal

FIGURE 2-2 RECTANGULAR DUCT/LONGITUDINAL SEAMS

Longitudinal Seams

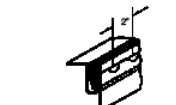

L-1
PITTSBURGH LOCK

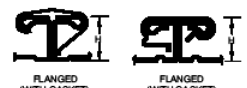
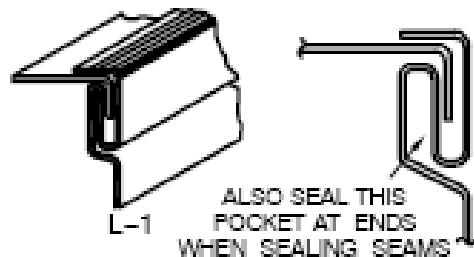
- Pocket depth from $\frac{1}{4}$ in. to $\frac{5}{8}$ in.
- Use on straight duct and fittings
- To ± 10 in. wg

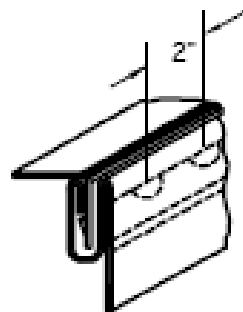

L-2
BUTTON PUNCH SNAP LOCK

- $\frac{5}{8}$ in. pocket depth for 20, 22, and 24 ga
- $\frac{1}{2}$ in. pocket depth for 24 and 26 ga
- To ± 4 in. wg
- Screws must be added at the ends of all duct of 4 in. wg and at the ends of 3 in. wg when the duct is over 48 in. width

Longitudinal Seams



L-3
GROOVED SEAM
ALSO CALLED FLAT LOCK AND PIPE LOCK

- To ± 10 in. wg

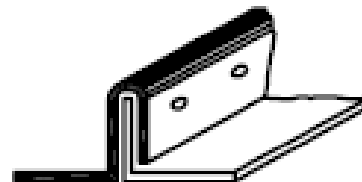

SEE FIG. 2-7 ALSO

L-4 STANDING SEAM

- To ± 10 in. wg
- 1 in. seam up to duct width of 42 in.
- 1 ½ in. seam for larger ducts
- May be used on duct interiors
- Fasten at 2 in. maximum from ends and at 8 in. maximum intervals

Longitudinal Seams

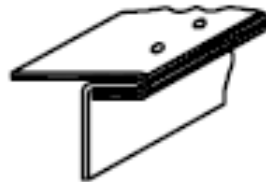

L-5 SINGLE CORNER SEAM

- To ± 10 in. wg
- Fasten as per L-4



FLANGED
(WITH GASKET)
T-25a



FLANGED
(WITH GASKET)
T-25b

- Assemble per Figure 2-17
- Ratings may be adjusted with EI-rated bar stock or members from Tables 2-29 and 2-30
- Supplemental members may be attached to the duct wall on both sides of the joint
- Single members may be used if they are fastened through both mating flanges
- Gasket to be located to form an effective seal

Intermediate Reinforcement

- Figure 2-3
- Page 2.12

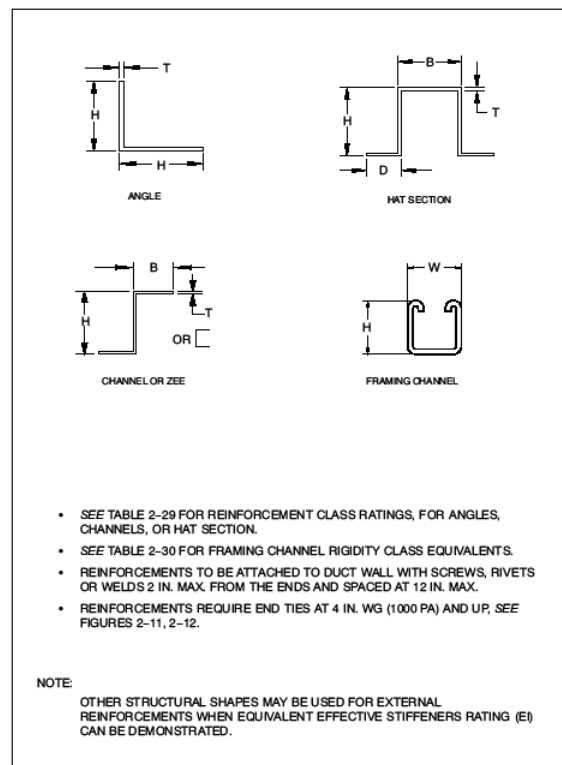
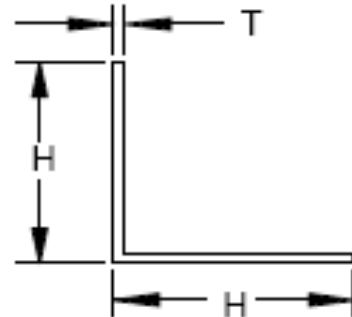

FIGURE 2-3 RECTANGULAR DUCT EXTERNAL REINFORCEMENTS

Rectangular

Intermediate Reinforcement



ANGLE

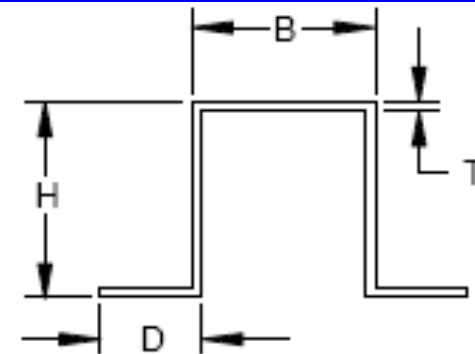

HAT SECTION

- SEE TABLE 2-29 FOR REINFORCEMENT CLASS RATINGS, FOR ANGLES, CHANNELS, OR HAT SECTION.
- SEE TABLE 2-30 FOR FRAMING CHANNEL RIGIDITY CLASS EQUIVALENTS.

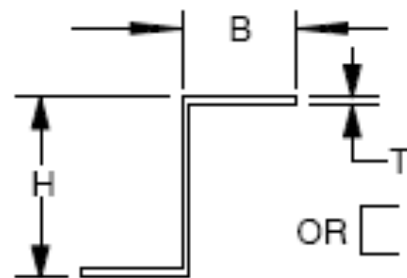

CHANNEL OR ZEE

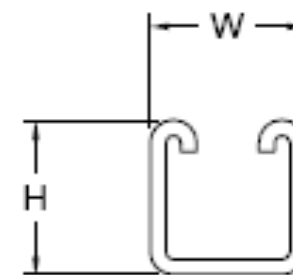

FRAMING CHANNEL



Basic Duct Construction Process

- Verify pressure class
- Check corresponding table
- Start with the larger side first
- Determine reinforcement spacing options
- Check joint reinforcement tables
- Check intermediate reinforcement tables if applicable (*tie rod options next webinar*)
- Repeat for the short side

Guide Summary (P 2.5)

READING GUIDE SUMMARY

Example: 54" x 18" duct, 5 ft. joint spacing. On 54" sides use F joints on 22 ga. On 18" sides flat slips or drives qualify per column 2.

Example: 54" x 30" duct, 22 gage. Use F at 5 ft. on 54". On 30" use D at 5 ft. or E at 10 ft. If you put joints on the 30" side at 5 ft. spacing, they must be D rated.

Joint Option: Backup member qualifies Hemmed "S" Slip - Reinforced or Drive Slip - Reinforced for letter code when selected from Table 2-29

Use Drive Slip or Hemmed "S" Slip on duct gage in column 2

Comment: If the table requires a letter code, all joints on that side must qualify for the minimum code letter related to the minimum gage and the spacing.

Spacing refers to letter code: use joint-to-joint, joint-to-intermediate or intermediate-to-intermediate. Columns 3 to 10 are alternatives

The drive slip is accepted as being A, B, or C rated up to 20" length.

Joint Option: Backup member qualifies Hemmed "S" Slip - Reinforced or Drive Slip - Reinforced for letter code when selected from Table 2-29

OR

Joint Option: Backup member qualifies Hemmed "S" Slip - Reinforced or Drive Slip - Reinforced for letter code when selected from Table 2-29

OR

Joint Option: Backup member qualifies Hemmed "S" Slip - Reinforced or Drive Slip - Reinforced for letter code when selected from Table 2-29

TABLE 2-31 (Option) TRANSVERSE JOINT

TABLE 2-29 (Option) INTERMEDIATE

TABLE 2-28 (Option) INTERMEDIATE

See Section 2.1.2. Circles in the Table denote only column numbers. For column 2, see Fig. 2-8. For columns 3 through 6, see Introduction to Schedule. The number in the box is minimum gage; the first letter in the box is the minimum reinforcement grade for joints and intermediate spacing at a maximum spacing indicated in the column heading. A rating such as 10/20 means that the V may be downed to G with tie rod. At higher pressures and large widths, a reinforcement such as B means that only the rolled members are given.

- Circles are column numbers
- Number in box is the minimum gage
- First letter is minimum reinforcement class required.
- Second letter is downsized reinforcement when used with tie rod
- Xt – t means tie rod is required



In Words...

- If the box in the table shows H-20G
- The minimum panel gage is 20
- The reinforcement required is class H at the spacing noted at the top of the column (this can be a joint or intermediate reinforcement)
- You can use G instead of H if you use a tie rod as well. (If to achieve a class G you are already required to use a tie rod then you can not use this option)



Rectangular Duct Reinforcement

2 in. wg Static Pos. or Neg.	No Reinforcement Required	Reinforcement Code for Duct Gage Number							
		Reinforcement Spacing Options							
		10 ft	8 ft	6 ft	5 ft	4 ft	3 ft	2½ ft	2 ft
① Duct Dimension	②	③	④	⑤	⑥	⑦	⑧	⑨	⑩
10 in. and under	26 ga.	Not Required							
11 – 12 in.	26 ga.								
13 – 14 in.	24 ga.		B-26	B-26	B-26	B-26	B-26	B-26	B-26
15 – 16 in.	24 ga.		C-26	C-26	C-26	C-26	C-26	B-26	B-26
17 – 18 in.	22 ga.		C-26	C-26	C-26	C-26	C-26	C-26	B-26
19 – 20 in.	20 ga.	C-22	C-24	C-26	C-26	C-26	C-26	C-26	C-26
21 – 22 in.	18 ga.	D-22	D-24	D-26	D-26	C-26	C-26	C-26	C-26
23 – 24 in.	18 ga.	E-22	E-24	D-26	D-26	D-26	C-26	C-26	C-26
25 – 26 in.	18 ga.	E-22	E-22	E-24	D-26	D-26	C-26	C-26	C-26
27 – 28 in.	18 ga.	F-20	E-20	E-22	E-24	D-26	D-26	C-26	C-26
29 – 30 in.	18 ga.	F-20	F-20	E-22	E-24	E-26	D-26	D-26	C-26
31 – 36 in.	16 ga.	G-18	G-20	F-22	F-24	E-24	E-26	D-26	D-26
37 – 42 in.		H-16	H-18	G-20	G-22	F-24	E-24	E-26	E-26
43 – 48 in.			I-18	H-20	H-22	G-22	F-24	F-24	E-24
49 – 54 in.			I-16G	I-18G	H-20G	H-20G	G-24	F-24	F-24
55 – 60 in.				I-18G	I-20G	H-20G	G-22	G-24	F-24



Rectangular Duct Reinforcement

2 in. wg Static Pos. or Neg.	No Reinforcement Required	Reinforcement Code for Duct Gage Number							
		Reinforcement Spacing Options							
		10 ft	8 ft	6 ft	5 ft	4 ft	3 ft	2½ ft	2 ft
① Duct Dimension	②	③	④	⑤	⑥	⑦	⑧	⑨	⑩
10 in. and under	26 ga.	Not Required							
11 – 12 in.	26 ga.								
13 – 14 in.	24 ga.		B-26	B-26	B-26	B-26	B-26	B-26	B-26
15 – 16 in.	24 ga.		C-26	C-26	C-26	C-26	C-26	B-26	B-26
17 – 18 in.	22 ga.		C-26	C-26	C-26	C-26	C-26	C-26	B-26
19 – 20 in.	20 ga.	C-22	C-24	C-26	C-26	C-26	C-26	C-26	C-26
21 – 22 in.	18 ga.	D-22	D-24	D-26	D-26	C-26	C-26	C-26	C-26
23 – 24 in.	18 ga.	E-22	E-24	D-26	D-26	D-26	C-26	C-26	C-26
25 – 26 in.	18 ga.	E-22	E-22	E-24	D-26	D-26	C-26	C-26	C-26
27 – 28 in.	18 ga.	F-20	E-20	E-22	E-24	D-26	D-26	C-26	C-26
29 – 30 in.	18 ga.	F-20	F-20	E-22	E-24	E-26	D-26	D-26	C-26
31 – 36 in.	16 ga.	G-18	G-20	F-22	F-24	E-24	E-26	D-26	D-26
37 – 42 in.		H-16	H-18	G-20	G-22	F-24	E-24	E-26	E-26
43 – 48 in.			I-18	H-20	H-22	G-22	F-24	F-24	E-24
49 – 54 in.			I-16G	I-18G	H-20G	H-20G	G-24	F-24	F-24
55 – 60 in.				I-18G	I-20G	H-20G	G-22	G-24	F-24



Rectangular Duct Reinforcement

2 in. wg Static Pos. or Neg.	No Reinforcement Required	Reinforcement Code for Duct Gage Number							
		Reinforcement Spacing Options							
		10 ft	8 ft	6 ft	5 ft	4 ft	3 ft	2½ ft	2 ft
① Duct Dimension	②	③	④	⑤	⑥	⑦	⑧	⑨	⑩
10 in. and under	26 ga.	Not Required							
11 – 12 in.	26 ga.								
13 – 14 in.	24 ga.		B-26	B-26	B-26	B-26	B-26	B-26	B-26
15 – 16 in.	24 ga.		C-26	C-26	C-26	C-26	C-26	B-26	B-26
17 – 18 in.	22 ga.		C-26	C-26	C-26	C-26	C-26	C-26	B-26
19 – 20 in.	20 ga.	C-22	C-24	C-26	C-26	C-26	C-26	C-26	C-26
21 – 22 in.	18 ga.	D-22	D-24	D-26	D-26	C-26	C-26	C-26	C-26
23 – 24 in.	18 ga.	E-22	E-24	D-26	D-26	D-26	C-26	C-26	C-26
25 – 26 in.	18 ga.	E-22	E-22	E-24	D-26	D-26	C-26	C-26	C-26
27 – 28 in.	18 ga.	F-20	E-20	E-22	E-24	D-26	D-26	C-26	C-26
29 – 30 in.	18 ga.	F-20	F-20	E-22	E-24	E-26	D-26	D-26	C-26
31 – 36 in.	16 ga.	G-18	G-20	F-22	F-24	E-24	E-26	D-26	D-26
37 – 42 in.		H-16	H-18	G-20	G-22	F-24	E-24	E-26	E-26
43 – 48 in.			I-18	H-20	H-22	G-22	F-24	F-24	E-24
49 – 54 in.			I-16G	I-18G	H-20G	H-20G	G-24	F-24	F-24
55 – 60 in.				I-18G	I-20G	H-20G	G-22	G-24	F-24



Rectangular Duct Reinforcement

2 in. wg Static Pos. or Neg.	No Reinforcement Required	Reinforcement Code for Duct Gage Number							
		Reinforcement Spacing Options							
		10 ft	8 ft	6 ft	5 ft	4 ft	3 ft	2½ ft	2 ft
① Duct Dimension	②	③	④	⑤	⑥	⑦	⑧	⑨	⑩
10 in. and under	26 ga.	Not Required							
11 – 12 in.	26 ga.								
13 – 14 in.	24 ga.		B-26	B-26	B-26	B-26	B-26	B-26	B-26
15 – 16 in.	24 ga.		C-26	C-26	C-26	C-26	C-26	B-26	B-26
17 – 18 in.	22 ga.		C-26	C-26	C-26	C-26	C-26	C-26	B-26
19 – 20 in.	20 ga.	C-22	C-24	C-26	C-26	C-26	C-26	C-26	C-26
21 – 22 in.	18 ga.	D-22	D-24	D-26	D-26	C-26	C-26	C-26	C-26
23 – 24 in.	18 ga.	E-22	E-24	E-26	D-26	D-26	C-26	C-26	C-26
25 – 26 in.	18 ga.	E-22	E-22	E-24	D-26	D-26	C-26	C-26	C-26
27 – 28 in.	18 ga.	F-20	E-20	E-22	E-24	D-26	D-26	C-26	C-26
29 – 30 in.	18 ga.	F-20	F-20	E-22	E-24	E-26	D-26	D-26	C-26
31 – 36 in.	16 ga.	G-18	G-20	F-22	F-24	E-24	E-26	D-26	D-26
37 – 42 in.		H-16	H-18	G-20	G-22	F-24	E-24	E-26	E-26
43 – 48 in.			I-18	H-20	H-22	G-22	F-24	F-24	E-24
49 – 54 in.			I-16G	I-18G	H-20G	H-20G	G-24	F-24	F-24
55 – 60 in.				I-18G	I-20G	H-20G	G-22	G-24	F-24



Rectangular Duct Reinforcement

2 in. wg Static Pos. or Neg.	No Reinforcement Required	Reinforcement Code for Duct Gage Number							
		Reinforcement Spacing Options							
		10 ft	8 ft	6 ft	5 ft	4 ft	3 ft	2½ ft	2 ft
① Duct Dimension	②	③	④	⑤	⑥	⑦	⑧	⑨	⑩
10 in. and under	26 ga.	Not Required							
11 – 12 in.	26 ga.								
13 – 14 in.	24 ga.		B-26	B-26	B-26	B-26	B-26	B-26	B-26
15 – 16 in.	24 ga.		C-26	C-26	C-26	C-26	C-26	B-26	B-26
17 – 18 in.	22 ga.		C-26	C-26	C-26	C-26	C-26	C-26	B-26
19 – 20 in.	20 ga.	C-22	C-24	C-26	C-26	C-26	C-26	C-26	C-26
21 – 22 in.	18 ga.	D-22	D-24	D-26	D-26	C-26	C-26	C-26	C-26
23 – 24 in.	18 ga.	E-22	E-24	D-26	D-26	D-26	C-26	C-26	C-26
25 – 26 in.	18 ga.	E-22	E-22	E-24	D-26	D-26	C-26	C-26	C-26
27 – 28 in.	18 ga.	F-20	E-20	E-22	E-24	D-26	D-26	C-26	C-26
29 – 30 in.	18 ga.	F-20	F-20	E-22	E-24	E-26	D-26	D-26	C-26
31 – 36 in.	16 ga.	G-18	G-20	F-22	F-24	E-24	E-26	D-26	D-26
37 – 42 in.		H-16	H-18	G-20	G-22	F-24	E-24	E-26	E-26
43 – 48 in.			I-18	H-20	H-22	G-22	F-24	F-24	E-24
49 – 54 in.			I-16G	I-18G	H-20G	H-20G	G-24	F-24	F-24
55 – 60 in.				I-18G	I-20G	H-20G	G-22	G-24	F-24



Joint Reinforcement

- Table 2-31
- Starts on page 2.74
- Covers all transverse joints that qualify as reinforcement except T-1 drive slip
- For T-1 drive slip see Table 2-48 on page 2.110

Reinf. Class	T-2 Standing Drive Slip		T-10 Standing S		T-11 Standing S		T-12 Standing S		T-14 Standing S		
	H × T	WT LF	H × T	WT LF	H × T	WT LF	H × T	WT LF	H × T + HR	WT LF	
A	0.43	Use B	Use B		½ × 26 ga	0.5	Use B		Use D		
B	1.0	1 ½ × 26 ga	0.4	1 × 26 ga	0.6	½ × 22 ga 1 × 26 ga	0.6	1 × 26 ga	0.7	Use D	
C	1.9	1 ½ × 22 ga	0.6	1 × 22 ga	0.8	1 × 22 ga	0.8	1 × 24 ga	0.8	Use D	
D	2.7	1 ½ × 18 ga	0.8	1 ½ × 20 ga 1 × 22 ga (+)	0.9	1 × 20 ga 1 × 22 ga (+)	0.9	1 ½ × 22 ga	1.0	1 ½ × 24 ga 1 ½ × ½ Bar	1.4
E	6.5	NOT GIVEN	1 ½ × 18 ga	1.0	1 × 18 ga (+)	1.0	1 × 18 ga 1 ½ × 20 ga	1.2	Use F		
F	12.8		Use G					Use G		1 ½ × 22 ga 1 ½ × ½ Bar	1.5
G	15.8		1 ½ × 18 ga	1.3				1 ½ × 18 ga	1.3	1 ½ × 20 ga 1 ½ × ½ Bar	1.7
H	26.4									1 ½ × 18 ga 1 ½ × ½ Bar	2.0
I	69									2 ½ × 20 ga 2 × 2 × ¾ Angle	2.9
J	80									2 ½ × 20 ga 2 × 2 × ¾ Angle	3.7
K	103										
L	207										

Table 2-31 Transverse Joint Reinforcement

See Section 2.1.4. *Effective EI is number listed times 10⁵ before adjustment for bending moment capacity. T-2 and T-10 through T-14 are restricted to 30 in. length at 4 in. wg, to 36 in. length at 3 in. wg and are not recommended for service above 4 in. wg. (+) indicates positive pressure use only.

Joint Reinforcement

Reinf. Class	T-22 Companion Angles			T-24 Flanged		T-24a Flanged		T-25b Flanged	
	E1*	H x T	WT LF	T (Nom.)	WT LF	H x T (Nom.)	WT LF	H x T (Nom.)	WT LF
B	1.0	Use E		Use D		Use D		Use D	
C	1.9	Use E		Use D		Use D		Use D	
D	2.7	Use E		26 ga	0.5	1 x 22 ga	0.4	26 ga	0.5

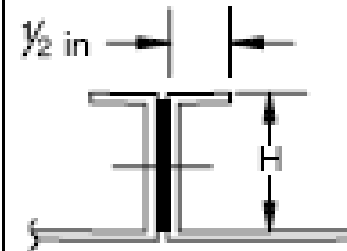
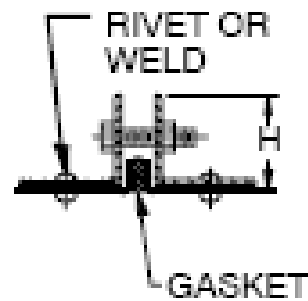

T-25a
Flanged



T-25b
Flanged

Joint Reinforcement

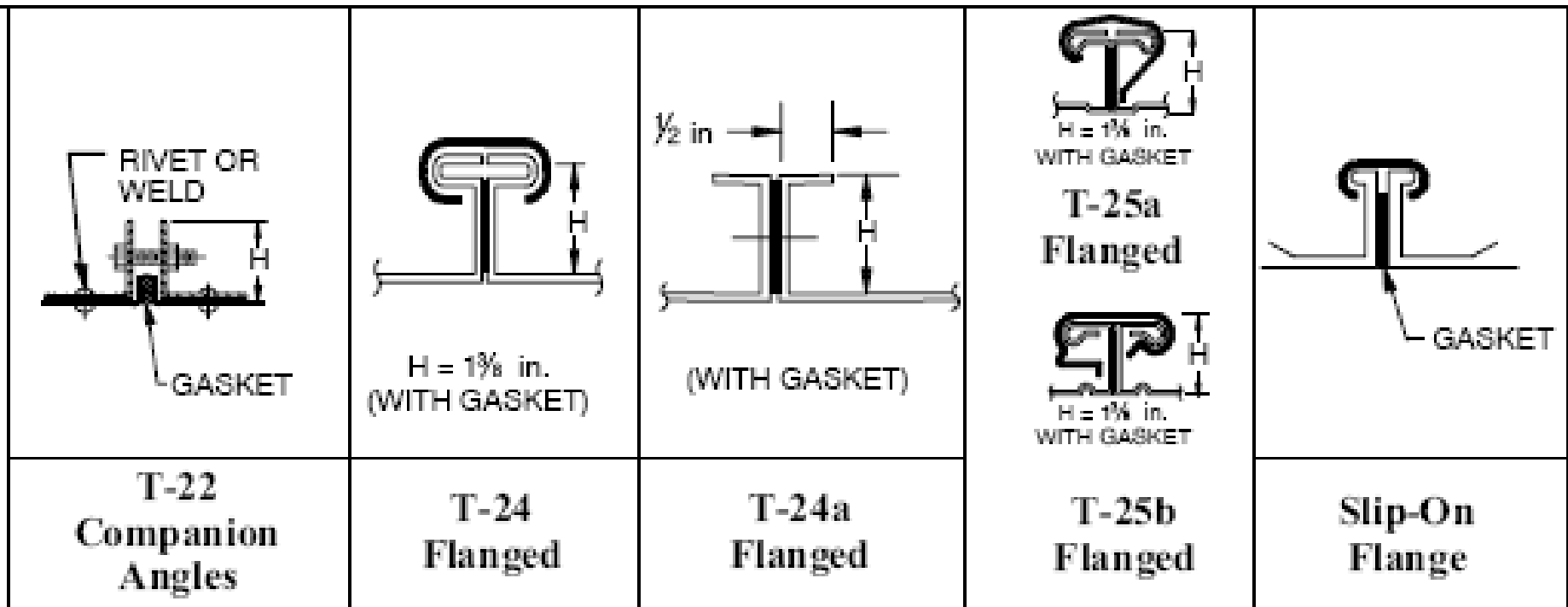

Reinf. Class		T-22 Companion Angles	T-24 Flanged	T-24a Flanged	T-25a Flanged	T-25b Flanged	Slip-On Flange
I	69	1½ × ¼	3.7	20 ga (R)	1.0	20 ga (R)	1.0
J	80	1½ × ¼ (+) 2 × ¼	4.7	18 ga (R)	1.1	18 ga (R)	1.1

SEE TIE ROD TEXT

The (R) means use with a tie rod

The (+) means use for positive pressure application only



Table 2-48

Duct Wall	26 ga		24 ga		22 ga		20 ga or Heavier	
Static Pressure	Maximum Duct Width (W) and Maximum Reinforcement Spacing (RS)							
	W	RS	W	RS	W	RS	W	RS
1/2 in. wg	20 in. 18 in.	10 ft N.R.	20 in.	N.R.	20 in.	N.R.	20 in.	N.R.
1 in. wg	20 in. 14 in. 12 in.	8 ft 10 ft N.R.	20 in. 14 in.	8 ft N.R.	20 in. 18 in.	10 ft N.R.	20 in.	N.R.
2 in. wg	18 in.	5 ft	18 in. 12 in.	8 ft N.R.	18 in. 14 in.	10 ft N.R.	18 in.	N.R.
3 in. wg	12 in. 10 in.	5 ft 6 ft	18 in. 10 in.	5 ft N.R.	18 in. 12 in.	5 ft N.R.	18 in. 14 in.	6 ft N.R.
4 in. wg	Not Accepted		16 in. 8 in.	5 ft N.R.	12 in. 8 in.	6 ft N.R.	12 in.	N.R.

Table 2-48 T-1 Flat Drive Accepted as Reinforcement



Example 1

- Pressure class is positive 1/2 in. w.g.
- Dimensions are 20 in. x 12 in.
- 5 ft. joint spacing (longer if possible)
- Preferred joint type plain Slip and Drive



Example 1

½ in. wg Static Pos. or Neg.	No Reinforcement Required	Reinforcement Code for Duct Gage Number							
		Reinforcement Spacing Options							
		10 ft	8 ft	6 ft	5 ft	4 ft	3 ft	2½ ft	2 ft
① Duct Dimension	②	③	④	⑤	⑥	⑦	⑧	⑨	⑩
10 in. and under	26 ga.	Not Required							
11 – 12 in.	26 ga.								
13 – 14 in.	26 ga.								
15 – 16 in.	26 ga.								
17 – 18 in.	26 ga.								
19 – 20 in.	24 ga.	B-26	B-26	B-26	B-26	B-26	B-26	A-26	A-26
21 – 22 in.	22 ga.	B-26	B-26	B-26	B-26	B-26	B-26	B-26	A-26



Example 1 Table 2-48

Duct Wall	26 ga		24 ga		22 ga		20 ga or Heavier	
Static Pressure	Maximum Duct Width (W) and Maximum Reinforcement Spacing (RS)							
	W	RS	W	RS	W	RS	W	RS
½ in. wg	20 in. 18 in.	10 ft N.R.	20 in.	N.R.	20 in.	N.R.	20 in.	N.R.
1 in. wg	20 in. 14 in. 12 in.	8 ft 10 ft N.R.	20 in. 14 in.	8 ft N.R.	20 in. 18 in.	10 ft N.R.	20 in.	N.R.
2 in. wg	18 in.	5 ft	18 in. 12 in.	8 ft N.R.	18 in. 14 in.	10 ft N.R.	18 in.	N.R.
3 in. wg	12 in. 10 in.	5 ft 6 ft	18 in. 10 in.	5 ft N.R.	18 in. 12 in.	5 ft N.R.	18 in. 14 in.	6 ft N.R.
4 in. wg	Not Accepted		16 in. 8 in.	5 ft N.R.	12 in. 8 in.	6 ft N.R.	12 in.	N.R.

Page
2.110

Table 2-48 T-1 Flat Drive Accepted as Reinforcement

Although the flat drive slip T-1 does not satisfy the EI calculation requirements for Classes A, B or C reinforcement, tests predict its suitability for use as reinforcement within the limits of the table.

N.R. – No reinforcement is required; however, the T-1 Joint may be used.



Example 1 Solutions

- Option 1
 - Use 24 gage
 - No reinforcement required either side
- Option 2
 - Use 26 gage
 - T-1 (plain drive) on the 20 in. side at a max spacing of 10 ft
 - No reinforcement required on the 12 in. side



Intermediate Reinforcement

- Table 2-29
- Starts on page 2.70
- Covers typical intermediate reinforcement types.
- For struts see Table 2-30 on page 2.72

Reinf. Class	Angle		Channel or Zee		Hat Section		
	E1*	H x T (MIN)	WT LF	H x B x T (MIN)	WT LF	H x B x D x T (MIN)	WT LF
A	0.43	Use C		Use B		Use F	
B	1.0	Use C		$\frac{3}{4} \times \frac{1}{2} \times 20$ ga	0.24	Use F	
C	1.9	C 1 x 16 ga C $\frac{3}{4} \times \frac{1}{2}$	0.40 0.57	$\frac{3}{4} \times \frac{1}{2} \times 18$ ga 1 x $\frac{3}{4} \times 20$ ga	0.31	Use F	
D	2.7	H $\frac{3}{4} \times \frac{1}{2}$ C 1 x $\frac{1}{2}$	0.57 0.80	1 x $\frac{3}{4} \times 18$ ga	0.45	Use F	
E	6.5	C 1 $\frac{1}{4} \times 12$ ga H 1 x $\frac{1}{2}$	0.90	2 x 1 $\frac{1}{2} \times 20$ ga	0.60	Use F	
F	12.8	H 1 $\frac{1}{4} \times \frac{1}{2}$	1.02	1 $\frac{1}{2} \times \frac{3}{4} \times 18$ ga	0.54	1 $\frac{1}{2} \times \frac{3}{4} \times \frac{5}{8} \times 18$ ga 1 $\frac{1}{2} \times 1 \frac{1}{2} \times \frac{3}{4} \times 20$ ga	0.90 0.83
G	15.8	1 $\frac{1}{2} \times \frac{1}{2}$	1.23	1 $\frac{1}{2} \times \frac{3}{4} \times 16$ ga	0.66	1 $\frac{1}{2} \times \frac{3}{4} \times \frac{5}{8} \times 18$ ga	0.80
H	26.4	1 $\frac{1}{2} \times \frac{3}{4}$ 2 x $\frac{1}{2}$	1.78 1.65	1 $\frac{1}{2} \times \frac{3}{4} \times \frac{1}{2}$	1.31	1 $\frac{1}{2} \times 1 \frac{1}{2} \times \frac{3}{4} \times 18$ ga 2 x 1 x $\frac{3}{4} \times 20$ ga	1.08 0.90
I	69	C 2 x $\frac{3}{8}$ 2 $\frac{1}{2} \times \frac{1}{2}$	2.44 2.10	2 x 1 $\frac{1}{2} \times 12$ ga 3 x 1 $\frac{1}{2} \times 16$ ga	1.60 1.05	2 x 1 x $\frac{3}{4} \times 16$ ga	1.44
J	80	H 2 x $\frac{3}{8}$ C 2 x $\frac{3}{4}$ 2 $\frac{1}{2} \times \frac{1}{2}$ (+)	2.44 3.20 2.10	2 x 1 $\frac{1}{2} \times \frac{1}{2}$	1.85	2 x 1 x $\frac{3}{4} \times 12$ ga 2 $\frac{1}{2} \times 2 \times \frac{3}{4} \times 18$ ga	2.45 1.53
K	103	2 $\frac{1}{2} \times \frac{3}{8}$	3.10	3 x 1 $\frac{1}{2} \times 12$ ga	2.00	2 $\frac{1}{2} \times 2 \times \frac{3}{4} \times 16$ ga 3 x 1 $\frac{1}{2} \times \frac{3}{4} \times 16$ ga	1.88 2.00
L	207	H 2 $\frac{1}{2} \times \frac{1}{4}$	4.10	3 x 1 $\frac{1}{2} \times \frac{1}{2}$	2.29	2 $\frac{1}{2} \times 2 \times \frac{3}{4} \times \frac{1}{2}$ 3 x 1 $\frac{1}{2} \times \frac{3}{4} \times 12$ ga	3.70 3.40

Table 2-29 Intermediate Reinforcement



Intermediate Reinforcement

Reinf. Class		Angle		Channel or Zee		Hat Section	
	E1*	H × T (MIN)	WT LF	H × B × T (MIN)	WT LF	H × B × D × T (MIN)	WT LF
A	0.43	Use C		Use B		Use F	
B	1.0	Use C		$\frac{3}{4} \times \frac{1}{2} \times 20$ ga	0.24	Use F	
C	1.9	C 1×16 ga C $\frac{3}{4} \times \frac{1}{8}$	0.40 0.57	$\frac{3}{4} \times \frac{1}{2} \times 18$ ga $1 \times \frac{3}{4} \times 20$ ga	0.31	Use F	
D	2.7	H $\frac{3}{4} \times \frac{1}{8}$ C $1 \times \frac{1}{8}$	0.57 0.80	$1 \times \frac{3}{4} \times 18$ ga	0.45	Use F	
E	6.5	C $1 \frac{1}{4} \times 12$ ga H $1 \times \frac{1}{8}$	0.90	$2 \times 1 \frac{1}{8} \times 20$ ga	0.60	Use F	
F	12.8	H $1 \frac{1}{4} \times \frac{1}{8}$	1.02	$1 \frac{1}{2} \times \frac{3}{4} \times 18$ ga	0.54	$1 \frac{1}{2} \times \frac{3}{4} \times \frac{5}{8} \times 18$ ga $1 \frac{1}{2} \times 1 \frac{1}{2} \times \frac{3}{4} \times 20$ ga	0.90 0.83

Intermediate Reinforcement

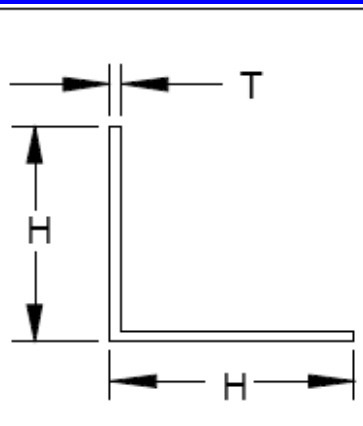
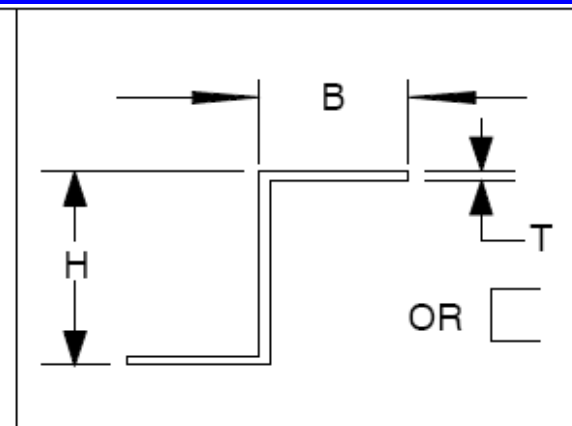
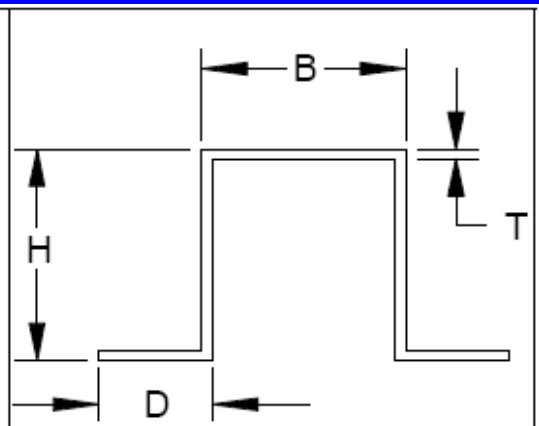
							
Reinf. Class		Angle		Channel or Zee		Hat Section	
	E1*	H × T (MIN)	WT LF	H × B × T (MIN)	WT LF	H × B × D × T (MIN)	WT LF
A	0.43	Use C		Use B		Use F	
B	1.0	Use C		$\frac{3}{4} \times \frac{1}{2} \times 20$ ga	0.24	Use F	
C	1.9	C 1×16 ga C $\frac{3}{4} \times \frac{1}{8}$	0.40 0.57				
D	2.7	H $\frac{3}{4} \times \frac{1}{8}$ C $1 \times \frac{1}{8}$	0.57 0.80				
E	6.5	C $1 \frac{1}{4} \times 12$ ga H $1 \times \frac{1}{8}$	0.90	$2 \times 1 \frac{1}{8} \times 20$ ga	0.60	Use F	
F	12.8	H $1 \frac{1}{4} \times \frac{1}{8}$	1.02	$1 \frac{1}{2} \times \frac{3}{4} \times 18$ ga	0.54	$1 \frac{1}{2} \times \frac{3}{4} \times \frac{5}{8} \times 18$ ga $1 \frac{1}{2} \times 1 \frac{1}{2} \times \frac{3}{4} \times 20$ ga	0.90 0.83

H denotes Hot formed
C denotes Cold formed



Example 2

- Pressure Class is 2 in. w.g.
- Dimensions are 60 in. x 26 in.
- 5 foot joint spacing
- TDC or TDF joint
- No internal reinforcement



The Right Table (Pressure Class)

2 in. wg Static Pos. or Neg.	No Reinforcement Required	Reinforcement Code for Duct Gage Number							
Duct Dimension		Reinforcement Spacing Options							
		10 ft	8 ft	6 ft	5 ft	4 ft	3 ft	2½ ft	2 ft
①	②	③	④	⑤	⑥	⑦	⑧	⑨	⑩
10 in. and under	26 ga.	Not Required							
11 – 12 in.	26 ga.								
13 – 14 in.	24 ga.		B-26	B-26	B-26	B-26	B-26	B-26	B-26
15 – 16 in.	24 ga.		C-26	C-26	C-26	C-26	C-26	B-26	B-26
17 – 18 in.	22 ga.		C-26	C-26	C-26	C-26	C-26	C-26	B-26
19 – 20 in.	20 ga.	C-22	C-24	C-26	C-26	C-26	C-26	C-26	C-26
21 – 22 in.	18 ga.	D-22	D-24	D-26	D-26	C-26	C-26	C-26	C-26
23 – 24 in.	18 ga.	E-22	E-24	D-26	D-26	D-26	C-26	C-26	C-26
25 – 26 in.	18 ga.	E-22	E-22	E-24	D-26	D-26	C-26	C-26	C-26
27 – 28 in.	18 ga.	F-20	E-20	E-22	E-24	D-26	D-26	C-26	C-26
29 – 30 in.	18 ga.	F-20	F-20	E-22	E-24	E-26	D-26	D-26	C-26
31 – 36 in.	16 ga.	G-18	G-20	F-22	F-24	E-24	E-26	D-26	D-26
37 – 42 in.		H-16	H-18	G-20	G-22	F-24	E-24	E-26	E-26
43 – 48 in.			I-18	H-20	H-22	G-22	F-24	F-24	E-24
49 – 54 in.			I-16G	I-18G	H-20G	H-20G	G-24	F-24	F-24
55 – 60 in.				I-18G	I-20G	H-20G	G-22	G-24	F-24



The Right Table (Pressure Class)

2 in. wg Static Pos. or Neg.	No Reinforcement Required	Reinforcement Code for Duct Gage Number							
		Reinforcement Spacing Options							
		10 ft	8 ft	6 ft	5 ft	4 ft	3 ft	2½ ft	2 ft
① Duct Dimension	②	③	④	⑤	⑥	⑦	⑧	⑨	⑩
10 in. and under	26 ga.	Not Required							
11 – 12 in.	26 ga.								
13 – 14 in.	24 ga.		B-26	B-26	B-26	B-26	B-26	B-26	B-26
15 – 16 in.	24 ga.		C-26	C-26	C-26	C-26	C-26	B-26	B-26
17 – 18 in.	22 ga.		C-26	C-26	C-26	C-26	C-26	C-26	B-26
19 – 20 in.	20 ga.	C-22	C-24	C-26	C-26	C-26	C-26	C-26	C-26
21 – 22 in.	18 ga.	D-22	D-24	D-26	D-26	C-26	C-26	C-26	C-26
23 – 24 in.	18 ga.	E-22	E-24	D-26	D-26	D-26	C-26	C-26	C-26
25 – 26 in.	18 ga.	E-22	E-22	E-24	D-26	D-26	C-26	C-26	C-26
27 – 28 in.	18 ga.	F-20	E-20	E-22	E-24	D-26	D-26	C-26	C-26
29 – 30 in.	18 ga.	F-20	F-20	E-22	E-24	E-26	D-26	D-26	C-26
31 – 36 in.	16 ga.	G-18	G-20	F-22	F-24	E-24	E-26	D-26	D-26
37 – 42 in.		H-16	H-18	G-20	G-22	F-24	E-24	E-26	E-26
43 – 48 in.			I-18	H-20	H-22	G-22	F-24	F-24	E-24
49 – 54 in.			I-16G	I-18G	H-20G	H-20G	G-24	F-24	F-24
55 – 60 in.				I-18G	I-20G	H-20G	G-22	G-24	F-24



The Right Table (Pressure Class)

2 in. wg Static Pos. or Neg.	No Reinforcement Required	Reinforcement Code for Duct Gage Number							
		Reinforcement Spacing Options							
		10 ft	8 ft	6 ft	5 ft	4 ft	3 ft	2½ ft	2 ft
① Duct Dimension	②	③	④	⑤	⑥	⑦	⑧	⑨	⑩
10 in. and under	26 ga.	Not Required							
11 – 12 in.	26 ga.								
13 – 14 in.	24 ga.		B-26	B-26	B-26	B-26	B-26	B-26	B-26
15 – 16 in.	24 ga.		C-26	C-26	C-26	C-26	C-26	B-26	B-26
17 – 18 in.	22 ga.		C-26	C-26	C-26	C-26	C-26	C-26	B-26
19 – 20 in.	20 ga.	C-22	C-24	C-26	C-26	C-26	C-26	C-26	C-26
21 – 22 in.	18 ga.	D-22	D-24	D-26	D-26	C-26	C-26	C-26	C-26
23 – 24 in.	18 ga.	E-22	E-24	D-26	D-26	D-26	C-26	C-26	C-26
25 – 26 in.	18 ga.	E-22	E-22	E-24	D-26	D-26	C-26	C-26	C-26
27 – 28 in.	18 ga.	F-20	E-20	E-22	E-24	D-26	D-26	C-26	C-26
29 – 30 in.	18 ga.	F-20	F-20	E-22	E-24	E-26	D-26	D-26	C-26
31 – 36 in.	16 ga.	G-18	G-20	F-22	F-24	E-24	E-26	D-26	D-26
37 – 42 in.		H-16	H-18	G-20	G-22	F-24	E-24	E-26	E-26
43 – 48 in.			I-18	H-20	H-22	G-22	F-24	F-24	E-24
49 – 54 in.			I-16G	I-18G	H-20G	H-20G	G-24	F-24	F-24
55 – 60 in.				I-18G	I-20G	H-20G	G-22	G-24	F-24

Joint Reinforcement

Reinf. Class	T-22 Companion Angles		T-24 Flanged		T-24a Flanged		T-25a Flanged		T-25b Flanged	
	E1*	H x T	WT LF	T (Nom.)	WT LF	H x T (Nom.)	WT LF	H x T (Nom.)	WT LF	
B	1.0	Use E		Use D		Use D		Use D		
C	1.9	Use E		Use D		Use D		Use D		
D	2.7	Use E		26 ga	0.5	1 x 22 ga	0.4	26 ga	0.5	
E	6.5	C 1 x 1/8	1.7	24 ga	0.6	Use F		24 ga	0.6	
F	12.8	H 1 x 1/8	1.7	22 ga	0.7	1 1/2 x 20 ga	0.6	22 ga	0.7	
G	15.8	1 1/4 x 1/8	2.1	22 ga (R) 20 G	1.0	1 1/2 x 18 ga	0.8	22 ga (R) 20 ga	1.0	
H	26.4	C 1 1/2 x 1/8 (+) H 1 1/2 x 1/8	2.6	18 ga	1.1			18 ga	1.1	
I	69	1 1/2 x 1/4	3.7	20 ga (R)	1.0			20 ga (R)	1.0	

Joint Reinforcement

Reinf. Class	T-22 Companion Angles		T-24 Flanged		T-24a Flanged		T-25a Flanged		T-25b Flanged	
	E1*	H x T	WT LF	T (Nom.)	WT LF	H x T (Nom.)	WT LF	H x T (Nom.)	WT LF	
B	1.0	Use E		Use D		Use D		Use D		
C	1.9	Use E		Use D		Use D		Use D		
D	2.7	Use E		26 ga	0.5	1 x 22 ga	0.4	26 ga	0.5	
E	6.5	C 1 x 1/8	1.7	24 ga	0.6	Use F		24 ga	0.6	
F	12.8	H 1 x 1/8	1.7	22 ga	0.7	1 1/2 x 20 ga	0.6	22 ga	0.7	
G	15.8	1 1/4 x 1/8	2.1	22 ga (R) 20 G	1.0	1 1/2 x 18 ga	0.8	22 ga (R) 20 ga	1.0	
H	26.4	C 1 1/2 x 1/8 (+) H 1 1/2 x 1/8	2.6	18 ga	1.1			18 ga	1.1	
I	69	1 1/2 x 1/4	3.7	20 ga (R)	1.0			20 ga (R)	1.0	

Page 2.76

Consumers establish formation text S

Intermediate Reinforcement

Reinf. Class		Angle		Channel or Zee		Hat Section	
	E1*	H x T (MIN)	WT LF	H x B x T (MIN)	WT LF	H x B x D x T (MIN)	WT LF
A	0.43	Use C		Use B		Use F	
B	1.0	Use C		$\frac{3}{4} \times \frac{1}{2} \times 20$ ga	0.24	Use F	
C	1.9	C 1×16 ga C $\frac{3}{4} \times \frac{1}{8}$	0.40 0.57	$\frac{3}{4} \times \frac{1}{2} \times 18$ ga $1 \times \frac{3}{4} \times 20$ ga	0.31	Use F	
D	2.7	H $\frac{3}{4} \times \frac{1}{8}$ C $1 \times \frac{1}{8}$	0.57 0.80	$1 \times \frac{3}{4} \times 18$ ga	0.45	Use F	
E	6.5	C $1 \frac{1}{4} \times 12$ ga H $1 \times \frac{1}{8}$	0.90	$2 \times 1 \frac{1}{8} \times 20$ ga	0.60	Use F	
F	12.8	H $1 \frac{1}{4} \times \frac{1}{8}$	1.02	$1 \frac{1}{2} \times \frac{3}{4} \times 18$ ga	0.54	$1 \frac{1}{2} \times \frac{3}{4} \times \frac{5}{8} \times 18$ ga $1 \frac{1}{2} \times 1 \frac{1}{2} \times \frac{3}{4} \times 20$ ga	0.90 0.83
G	15.8	$1 \frac{1}{2} \times \frac{1}{8}$	1.23	$1 \frac{1}{2} \times \frac{3}{4} \times 16$ ga	0.66	$1 \frac{1}{2} \times \frac{3}{4} \times \frac{5}{8} \times 18$ ga	0.80
H	26.4	$1 \frac{1}{2} \times \frac{3}{16}$	1.78	$1 \frac{1}{2} \times \frac{3}{4} \times 14$	1.01	$1 \frac{1}{2} \times 1 \frac{1}{2} \times \frac{3}{4} \times 18$ ga	1.08

Intermediate Reinforcement

Reinf. Class		Angle		Channel or Zee		Hat Section	
	E1*	H x T (MIN)	WT LF	H x B x T (MIN)	WT LF	H x B x D x T (MIN)	WT LF
A	0.43	Use C		Use B		Use F	
B	1.0	Use C		$\frac{3}{4} \times \frac{1}{2} \times 20$ ga	0.24	Use F	
C	1.9	C 1×16 ga C $\frac{3}{4} \times \frac{1}{8}$	0.40 0.57	$\frac{3}{4} \times \frac{1}{2} \times 18$ ga $1 \times \frac{3}{4} \times 20$ ga	0.31	Use F	
D	2.7	H $\frac{3}{4} \times \frac{1}{8}$ C $1 \times \frac{1}{8}$	0.57 0.80	$1 \times \frac{3}{4} \times 18$ ga	0.45	Use F	
E	6.5	C $1 \frac{1}{4} \times 12$ ga H $1 \times \frac{1}{8}$	0.90	$2 \times 1 \frac{1}{8} \times 20$ ga	0.60	Use F	
F	12.8	H $1 \frac{1}{4} \times \frac{1}{8}$	1.02	$1 \frac{1}{2} \times \frac{3}{4} \times 18$ ga	0.54	$1 \frac{1}{2} \times \frac{3}{4} \times \frac{5}{8} \times 18$ ga $1 \frac{1}{2} \times 1 \frac{1}{2} \times \frac{3}{4} \times 20$ ga	0.90 0.83
G	15.8	$1 \frac{1}{2} \times \frac{1}{8}$	1.23	$1 \frac{1}{2} \times \frac{3}{4} \times 16$ ga	0.66	$1 \frac{1}{2} \times \frac{3}{4} \times \frac{5}{8} \times 18$ ga	0.80
H	26.4	$1 \frac{1}{2} \times \frac{3}{16}$	1.78	$1 \frac{1}{2} \times \frac{3}{4} \times 14$	1.01	$1 \frac{1}{2} \times 1 \frac{1}{2} \times \frac{3}{4} \times 18$ ga	1.08



Intermediate Reinforcement

Channel (Strut)			Reinforcement Class Per Table 2-29
H	W	GA	
$1\frac{3}{16}$ in.	$1\frac{3}{16}$ in.	19	A, B, C
$1\frac{3}{16}$ in.	$1\frac{5}{8}$ in.	14	D
$\frac{7}{8}$ in.	$1\frac{5}{8}$ in.	12	D, E
$1\frac{3}{8}$ in.	$1\frac{5}{8}$ in.	12	F, G
$2\frac{1}{16}$ in.	$1\frac{7}{8}$ in.	12	H, I, J
$3\frac{1}{4}$ in.	$1\frac{5}{8}$ in.	12	K, L

Table 2-30 Framing Channel

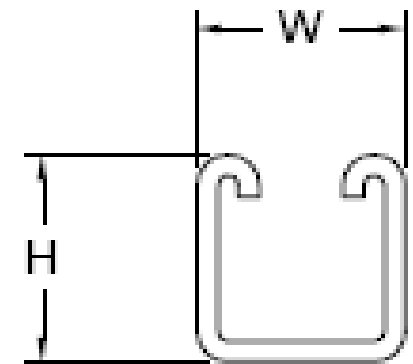



The Right Table (Pressure Class)

2 in. wg Static Pos. or Neg.	No Reinforcement Required	Reinforcement Code for Duct Gage Number							
		Reinforcement Spacing Options							
		10 ft	8 ft	6 ft	5 ft	4 ft	3 ft	2½ ft	2 ft
① Duct Dimension	②	③	④	⑤	⑥	⑦	⑧	⑨	⑩
10 in. and under	26 ga.	Not Required							
11 – 12 in.	26 ga.								
13 – 14 in.	24 ga.		B-26	B-26	B-26	B-26	B-26	B-26	B-26
15 – 16 in.	24 ga.		C-26	C-26	C-26	C-26	C-26	B-26	B-26
17 – 18 in.	22 ga.		C-26	C-26	C-26	C-26	C-26	C-26	B-26
19 – 20 in.	20 ga.	C-22	C-24	C-26	C-26	C-26	C-26	C-26	C-26
21 – 22 in.	18 ga.	D-22	D-24	D-26	D-26	C-26	C-26	C-26	C-26
23 – 24 in.	18 ga.	E-22	E-24	D-26	D-26	D-26	C-26	C-26	C-26
25 – 26 in.	18 ga.	E-22	E-22	E-24	D-26	D-26	C-26	C-26	C-26
27 – 28 in.	18 ga.	F-20	E-20	E-22	E-24	D-26	D-26	C-26	C-26
29 – 30 in.	18 ga.	F-20	F-20	E-22	E-24	E-26	D-26	D-26	C-26
31 – 36 in.	16 ga.	G-18	G-20	F-22	F-24	E-24	E-26	D-26	D-26
37 – 42 in.		H-16	H-18	G-20	G-22	F-24	E-24	E-26	E-26
43 – 48 in.			I-18	H-20	H-22	G-22	F-24	F-24	E-24
49 – 54 in.			I-16G	I-18G	H-20G	H-20G	G-24	F-24	F-24
55 – 60 in.				I-18G	I-20G	H-20G	G-22	G-24	F-24

Joint Reinforcement

Reinf. Class	T-22 Companion Angles			T-24 Flanged		T-24a Flanged		T-25b Flanged	
	E1*	H x T	WT LF	T (Nom.)	WT LF	H x T (Nom.)	WT LF	H x T (Nom.)	WT LF
B	1.0	Use E		Use D		Use D		Use D	
C	1.9	Use E		Use D		Use D		Use D	
D	2.7	Use E		26 ga	0.5	1 x 22 ga	0.4	26 ga	0.5
E	6.5	C 1 x 1/8	1.7	24 ga	0.6	Use F		24 ga	0.6
F	12.8	H 1 x 1/8	1.7	22 ga	0.7	1 1/2 x 20 ga	0.6	22 ga	0.7
G	15.8	1 1/4 x 1/8	2.1	22 ga (R) 20 G	1.0	1 1/2 x 18 ga	0.8	22 ga (R) 20 ga	1.0
H	26.4	C 1 1/2 x 1/8 (+) H 1 1/2 x 1/8	2.6	18 ga	1.1			18 ga	1.1
I	69	1 1/2 x 1/4	3.7	20 ga (R)	1.0			20 ga (R)	1.0



Example 2 Solution

- Duct gage is 20
- Joint spacing is 5 feet (56 ¼ in.)
- TDC/TDF for transverse joint
- Intermediate reinforcement (2 ½ feet)
 - G class
 - Angle 1 ½ x 1 ½ x 1/8
 - Not required on the 26 in. side



Intermediate External Reinforcement

- Reinforcement Intervals do not need to coincide
- At 4 in. positive pressure and above reinforcements must be tied
- Must be fastened to the duct within 2 in. from the corner (unless tied)
- Maximum fastener spacing is 12 in.

Reinforced on Two Sides

FIGURE 2-10 DUCT REINFORCED ON TWO SIDES

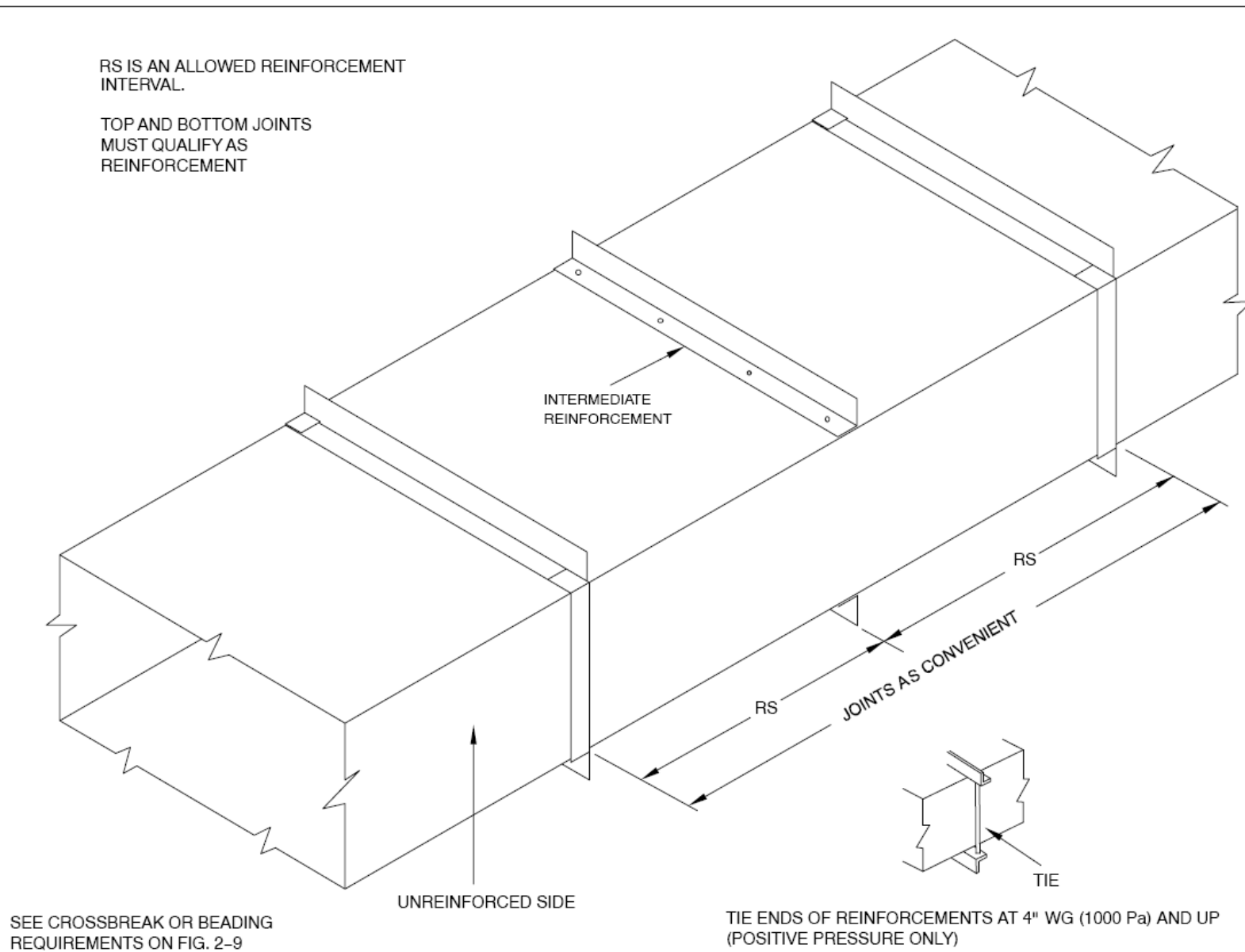

Reinforced on Two Sides

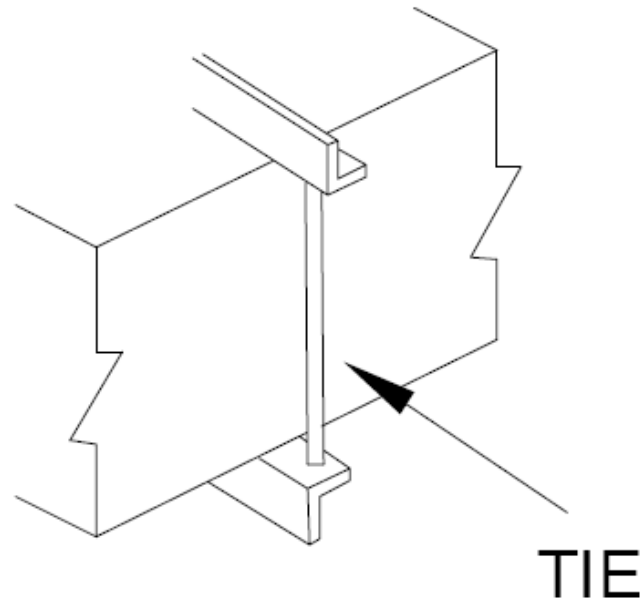

TIE ENDS OF REINFORCEMENTS AT 4" WG (1000 Pa) AND UP
(POSITIVE PRESSURE ONLY)



Reinforced on Four Sides

FIGURE 2-11 DUCT REINFORCED ON ALL SIDES

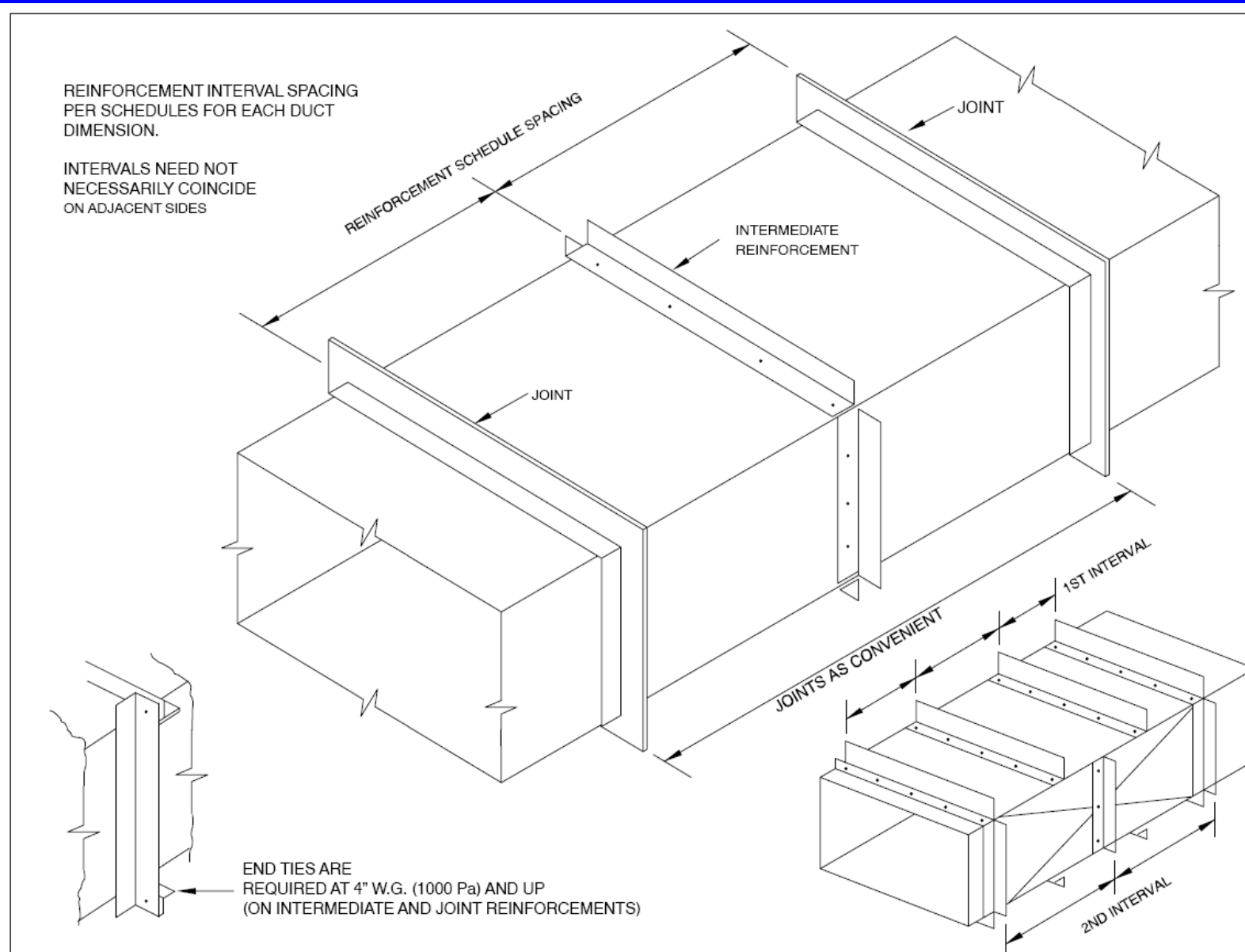

Reinforced on Four Sides

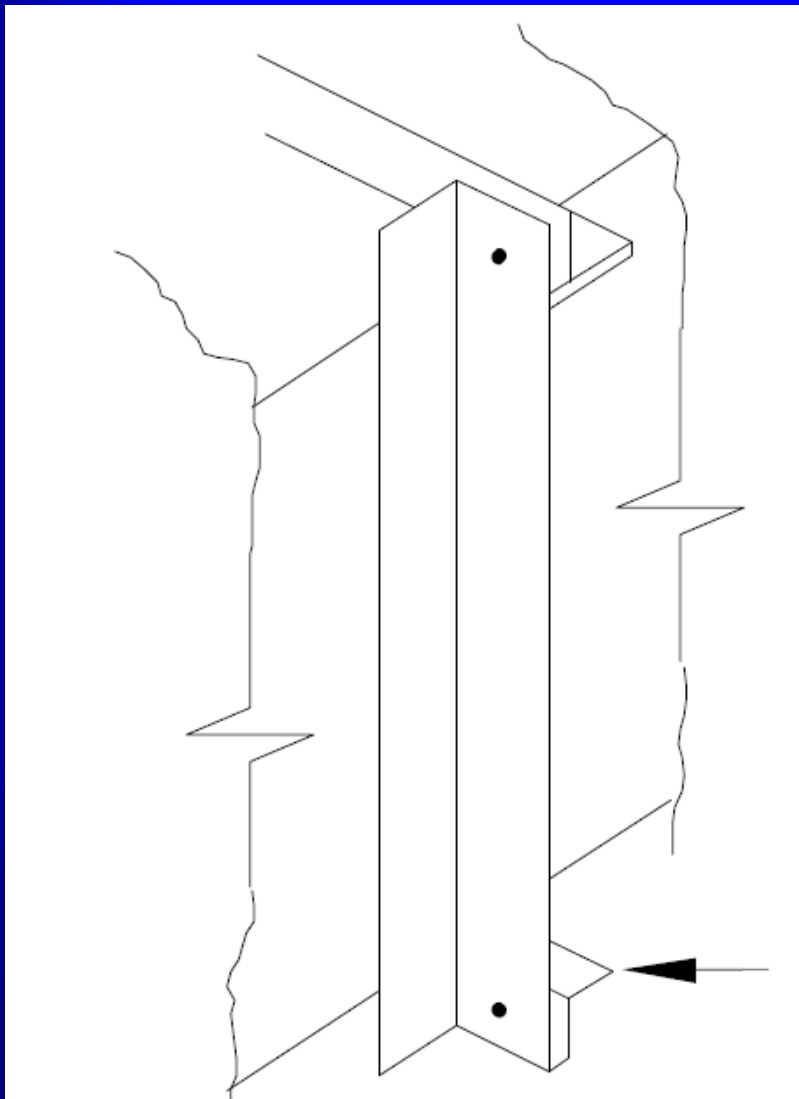

END TIES ARE
REQUIRED AT 4" W.G. (1000 Pa) AND UP
(ON INTERMEDIATE AND JOINT REINFORCEMENTS)

Reinforced on Four Sides

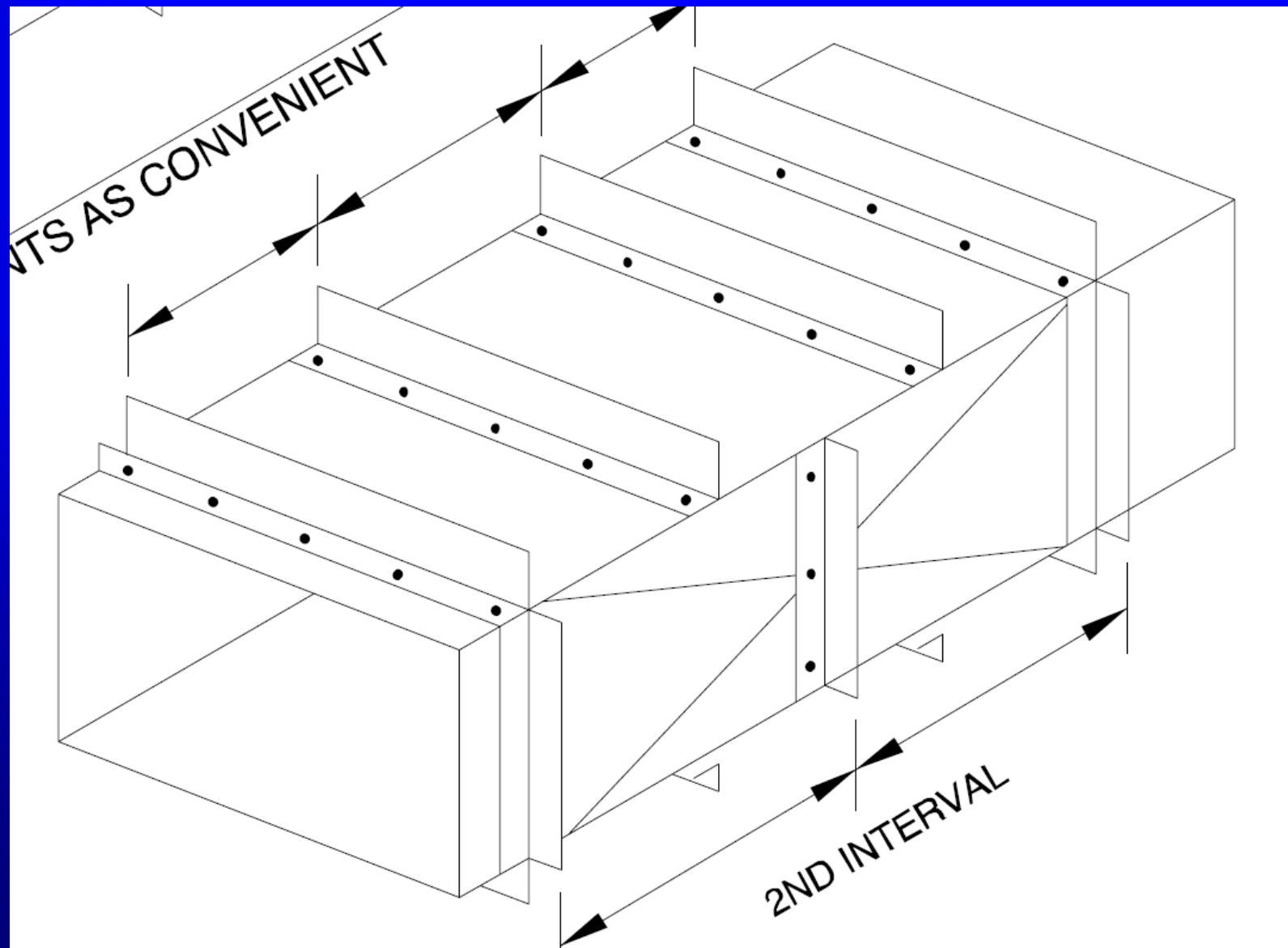

Reinforcement Attachment

X=12" (305 mm) MAXIMUM FASTENER (TACK WELD*, SPOTWELD, BOLT, SCREW, OR RIVET) SPACING.
WHEN END TIES ARE USED THE 2" (51 mm) INTERVAL MAY BE OMITTED.

WHEN REINFORCEMENTS OCCUR AT THE SAME LOCATION ON ADJACENT SIDES AT 4" W.G. (1000 Pa) STATIC AND OVER, TIE THE ENDS WITH 5/16" (8 mm) BOLTS OR RIVETS OR ADEQUATE WELDS. WHEN WELDING USE TWO PARALLEL WELDS.

* TACK WELD ALONG ALTERNATE SIDES OF THE MEMBER

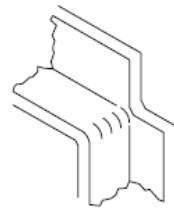
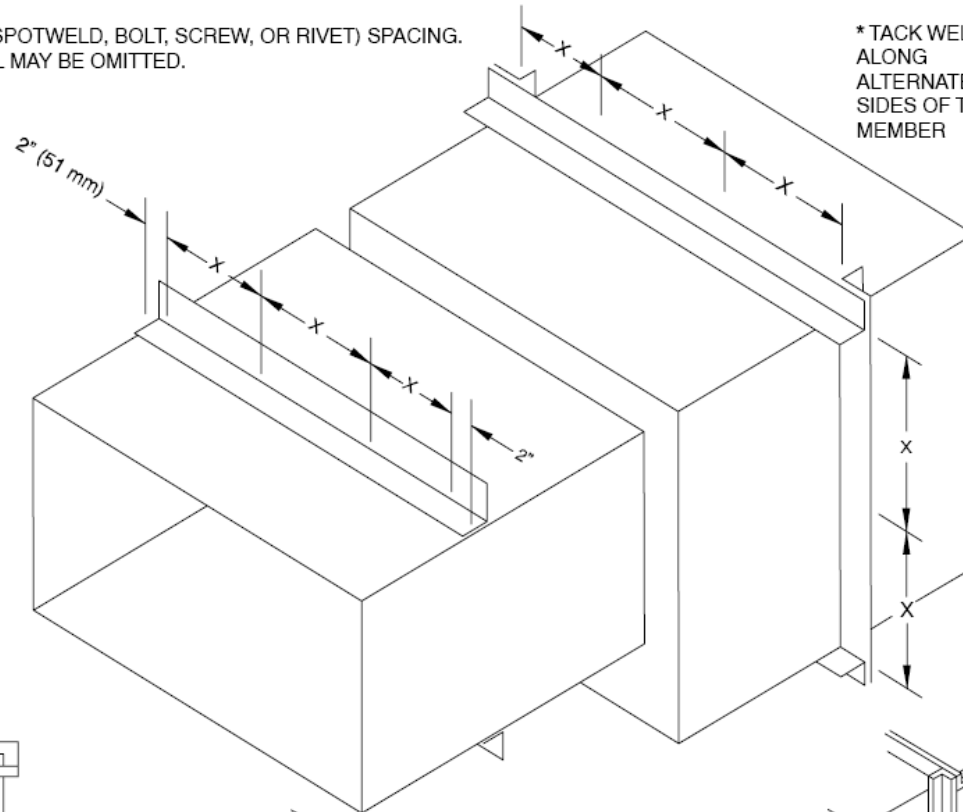

ALTERNATIVE CORNER TIE

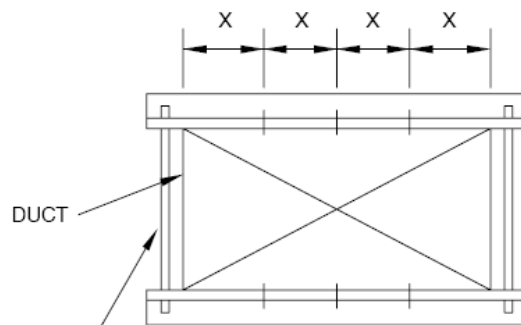

TIE REQUIRED OUTSIDE OF DUCT ON TWO-SIDE REINF. AT 4" WG (1000 Pa) AND OVER (POSITIVE PRESSURE ONLY)

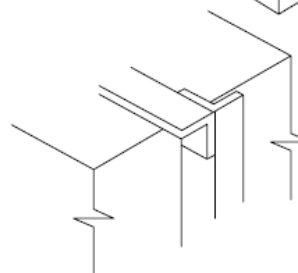

NEGATIVE PRESSURE OPTION

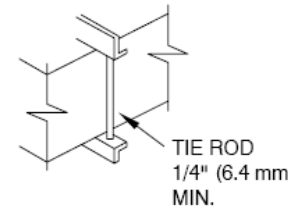

TIE ROD
1/4" (6.4 mm)
MIN.

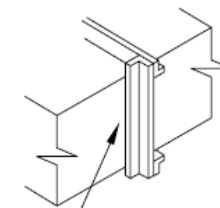

ANGLE TIE
1" | 1" | 12 GA.
(2.5 | 2.5 | 2.75 mm)
MINIMUM

TIE ALTERNATIVES FOR TWO-SIDE REINF.

FIGURE 2-12 REINFORCEMENT ATTACHMENT

EI Ratings



FLANGED
(WITH GASKET)
T-25a



FLANGED
(WITH GASKET)
T-25b

- Assemble per Figure 2-17
- Ratings may be adjusted with EI-rated bar stock or members from Tables 2-29 and 2-30
- Supplemental members may be attached to the duct wall on both sides of the joint
- Single members may be used if they are fastened through both mating flanges
- Gasket to be located to form an effective seal

EI Ratings

Reinf. Class	T-22 Companion Angles		T-24 Flanged		T-24a Flanged		T-25a Flanged		T-25b Flanged	
	H x T	WT LF	T (Nom.)	WT LF	H x T (Nom.)	WT LF	H x T (Nom.)	WT LF	H x T (Nom.)	WT LF
B	1.0	Use E		Use D		Use D		Use D		Use D
C	1.9	Use E		Use D		Use D		Use D		Use D
D	2.7	Use E		26 ga	0.5	1 x 22 ga	0.4	26 ga	0.5	0.5

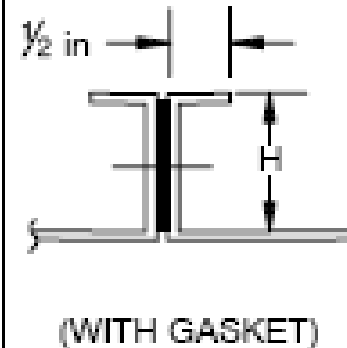
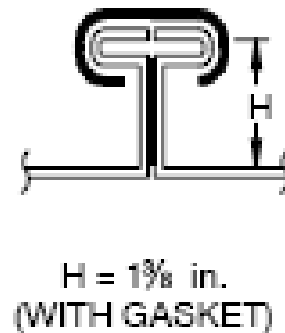
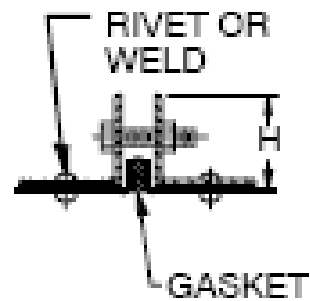

EI Ratings

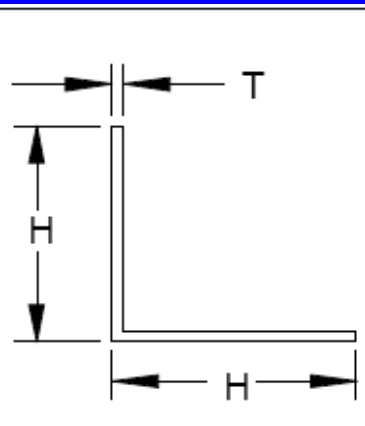
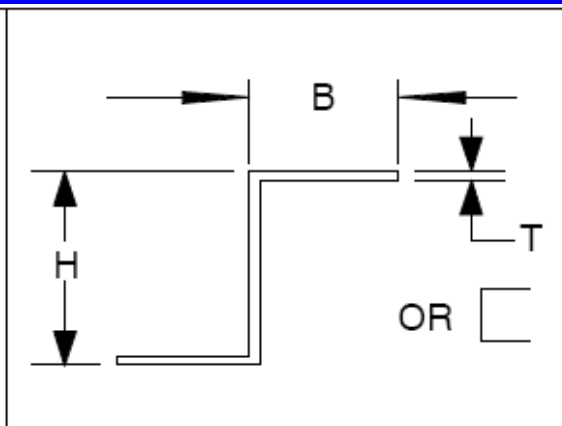
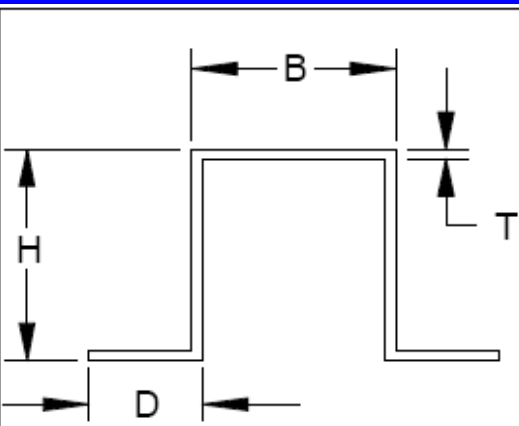
							
Reinf. Class		Angle		Channel or Zee		Hat Section	
	E1*	H × T (MIN)	WT LF	H × B × T (MIN)	WT LF	H × B × D × T (MIN)	WT LF
A	0.43	Use C		Use B		Use F	
B	1.0	Use C		$\frac{3}{4} \times \frac{1}{2} \times 20$ ga	0.24	Use F	
C	1.9	C 1 × 16 ga C $\frac{3}{4} \times \frac{1}{8}$	0.40 0.57	$\frac{3}{4} \times \frac{1}{2} \times 18$ ga 1 × $\frac{3}{4} \times 20$ ga	0.31	Use F	
D	2.7	H $\frac{3}{4} \times \frac{1}{8}$ C 1 × $\frac{1}{8}$	0.57 0.80	1 × $\frac{3}{4} \times 18$ ga	0.45	Use F	
E	6.5	C 1 $\frac{1}{4} \times 12$ ga H 1 × $\frac{1}{8}$	0.90	2 × 1 $\frac{1}{8} \times 20$ ga	0.60	Use F	
F	12.8	H 1 $\frac{1}{4} \times \frac{1}{8}$	1.02	1 $\frac{1}{2} \times \frac{3}{4} \times 18$ ga	0.54	1 $\frac{1}{2} \times \frac{3}{4} \times \frac{5}{8} \times 18$ ga 1 $\frac{1}{2} \times 1 \frac{1}{2} \times \frac{3}{4} \times 20$ ga	0.90 0.83



Example 3

- Pressure class negative 4 in. w.g.
- Size 36 x 30
- 5 ft joint using TDC/TDF
- External reinforcement only



Example 3

4 in. wg Static Pos. or Neg.	No Reinforcement Required	Reinforcement Code for Duct Gage Number							
		Reinforcement Spacing Options							
		10 ft	8 ft	6 ft	5 ft	4 ft	3 ft	2½ ft	2 ft
① Duct Dimension	②	③	④	⑤	⑥	⑦	⑧	⑨	⑩
8 in. and under	24 ga.	Not Required		B-26	B-26	B-26	B-26	B-26	B-26
9 – 10 in.	22 ga.			B-24	B-26	B-26	B-26	B-26	B-26
11 – 12 in.	22 ga.		B-24	C-24	C-26	C-26	C-26	B-26	B-26
13 – 14 in.			C-22	C-22	C-24	C-26	C-26	C-26	C-26
15 – 16 in.			D-22	D-22	C-24	C-26	C-26	C-26	C-26
17 – 18 in.			D-22	D-22	D-24	D-26	C-26	C-26	C-26
19 – 20 in.	18 ga.		E-20	E-22	E-24	D-24	D-26	C-26	C-26
21 – 22 in.	18 ga.		E-20	E-20	E-24	E-24	D-26	D-26	C-26
23 – 24 in.	18 ga.		F-20	F-20	E-22	E-24	E-26	D-26	D-26
25 – 26 in.	16 ga.	G-18	G-18	F-20	F-22	E-24	E-26	E-26	D-26
27 – 28 in.	16 ga.	H-18G	G-18	G-20	F-22	F-24	E-26	E-26	D-26
29 – 30 in.	16 ga.	H-18G	H-18G	G-18	G-22	F-24	E-26	E-26	E-26
31 – 36 in.		J-16H	I-16G	H-18G	H-20	G-22	F-24	F-26	E-26

Page
2.22

5 ft

⑥

H-20

4 in. wg
Static
Pos. or Neg.

Duct
Dimension

①

No
Reinforcement
Required

②

③

Reinforcement Code for Duct Gage Number

Reinforcement Spacing Options

10 ft 8 ft 6 ft 5 ft 4 ft 3 ft 2½ ft 2 ft

④ ⑤ ⑥ ⑦ ⑧ ⑨ ⑩

Not Required B-26 B-26 B-26 B-26 B-26 B-26

B-24 B-26 B-26 B-26 B-26 B-26

B-24 C-24 C-26 C-26 C-26 B-26 B-26

C-22 C-22 C-24 C-26 C-26 C-26 C-26

D-22 D-22 C-24 C-26 C-26 C-26 C-26

D-22 D-22 D-24 D-26 C-26 C-26 C-26

E-20 E-22 E-24 D-24 D-26 C-26 C-26

E-20 E-20 E-24 E-24 D-26 D-26 C-26

F-20 F-20 E-22 E-24 E-26 D-26 D-26

G-18 G-18 F-20 F-22 E-24 E-26 E-26 D-26

H-18G G-18 G-20 F-22 F-24 E-26 E-26 D-26

H-18G H-18G G-18 G-22 F-24 E-26 E-26 E-26

J-16H I-16G H-18G H-20 G-22 F-24 F-26 E-26

Example 3

Reinf. Class	T-22 Companion Angles			T-24 Flanged		T-24a Flanged		T-25b Flanged	
	EI*	H × T	WT / LF	T (Nom.)	WT / LF	H × T (Nom.)	WT / LF	H × T (Nom.)	WT / LF
B	1.0	Use E		Use D		Use D		Use D	
C	1.9	Use E		Use D		Use D		Use D	
D	2.7	Use E		26 ga	0.5	1 × 22 ga	0.4	26 ga	0.5
E	6.5	C 1 × 1/8	1.7	24 ga	0.6	Use F		24 ga	0.6
F	12.8	H 1 × 1/8	1.7	22 ga	0.7	1 1/2 × 20 ga	0.6	22 ga	0.7
G	15.8	1 1/4 × 1/8	2.1	22 ga (R) 20 G	1.0	1 1/2 × 18 ga	0.8	22 ga (R) 20 ga	1.0
H	26.4	C 1 1/2 × 1/8 (+) H 1 1/2 × 1/8	2.6	18 ga	1.1			18 ga	1.1



Example 3

- You can use 20 gage for the panel
- TDC/TDF needs to be 18 gage to qualify as an “H”
- What can I “ADD” to 20 gage TDC/TDF to make it an “H”?
- To get an “H” EI = 26.4
- TDC/TDF @ 20 gage = “G” = 15.8



Example 3

- “H” – “G” = $26.4 - 15.8 = 10.6$
- If you use reinforcement on each side of the joint you can divide the 10.6 by 2
- $10.6/2 = 5.3$
- What has an EI of 5.3 (or more)?
- Class “E” has an EI of 6.5

EI Ratings

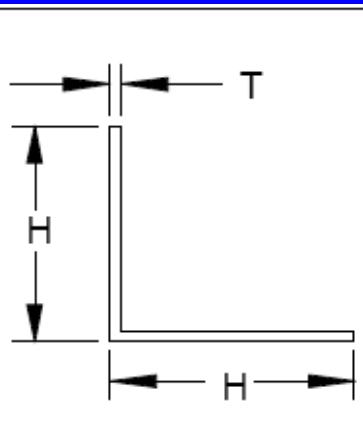
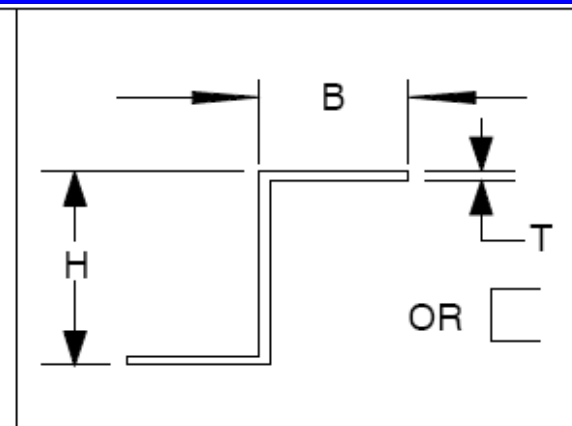
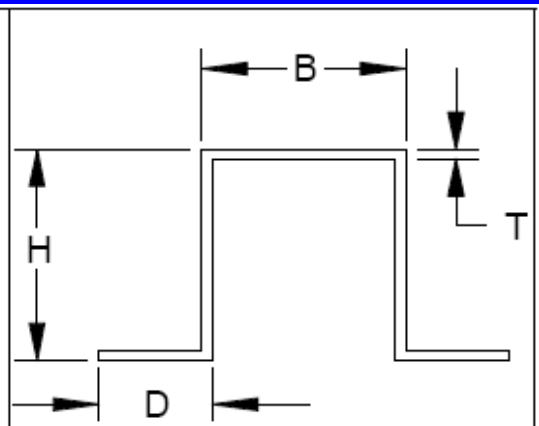
							
Reinf. Class		Angle		Channel or Zee		Hat Section	
	E1*	H × T (MIN)	WT LF	H × B × T (MIN)	WT LF	H × B × D × T (MIN)	WT LF
A	0.43	Use C		Use B		Use F	
B	1.0	Use C		$\frac{3}{4} \times \frac{1}{2} \times 20$ ga	0.24	Use F	
C	1.9	C 1×16 ga C $\frac{3}{4} \times \frac{1}{8}$	0.40 0.57	$\frac{3}{4} \times \frac{1}{2} \times 18$ ga $1 \times \frac{3}{4} \times 20$ ga	0.31	Use F	
D	2.7	H $\frac{3}{4} \times \frac{1}{8}$ C $1 \times \frac{1}{8}$	0.57 0.80	$1 \times \frac{3}{4} \times 18$ ga	0.45	Use F	
E	6.5	C $1 \frac{1}{4} \times 12$ ga H $1 \times \frac{1}{8}$	0.90	$2 \times 1 \frac{1}{8} \times 20$ ga	0.60	Use F	
F	12.8	H $1 \frac{1}{4} \times \frac{1}{8}$	1.02	$1 \frac{1}{2} \times \frac{3}{4} \times 18$ ga	0.54	$1 \frac{1}{2} \times \frac{3}{4} \times \frac{5}{8} \times 18$ ga $1 \frac{1}{2} \times 1 \frac{1}{2} \times \frac{3}{4} \times 20$ ga	0.90 0.83



Example 3

- SO...
- A “G” plus two “E”s =
- $15.8 + 2(6.5) = 28.8 = \text{“H”}$
- It’s actually a little bit more than the minimum value for “H” (EI = 26.4) but not enough to be an “I” (EI = 69)
- Check the short side (30”)...



Example 3

4 in. wg Static Pos. or Neg.	No Reinforcement Required	Reinforcement Code for Duct Gage Number							
		Reinforcement Spacing Options							
		10 ft	8 ft	6 ft	5 ft	4 ft	3 ft	2½ ft	2 ft
① Duct Dimension	②	③	④	⑤	⑥	⑦	⑧	⑨	⑩
8 in. and under	24 ga.	Not Required		B-26	B-26	B-26	B-26	B-26	B-26
9 – 10 in.	22 ga.	Not Required		B-24	B-26	B-26	B-26	B-26	B-26
11 – 12 in.			B-24	C-24	C-26	C-26	C-26	B-26	B-26
13 – 14 in.			C-22	C-22	C-24	C-26	C-26	C-26	C-26
15 – 16 in.			D-22	D-22	C-24	C-26	C-26	C-26	C-26
17 – 18 in.	18 ga.		D-22	D-22	D-24	D-26	C-26	C-26	C-26
19 – 20 in.	18 ga.		E-20	E-22	E-24	D-24	D-26	C-26	C-26
21 – 22 in.	18 ga.		E-20	E-20	E-24	E-24	D-26	D-26	C-26
23 – 24 in.	18 ga.		F-20	F-20	E-22	E-24	E-26	D-26	D-26
25 – 26 in.	16 ga.	G-18	G-18	F-20	F-22	E-24	E-26	E-26	D-26
27 – 28 in.	16 ga.	H-18G	G-18	G-20	F-22	F-24	E-26	E-26	D-26
29 – 30 in.	16 ga.	H-18G	H-18G	G-18	G-22	F-24	E-26	E-26	E-26
31 – 36 in.		J-16H	I-16G	H-18G	H-20	G-22	F-24	F-26	E-26

Page
2.22



Example 3

- The short side requires G-22
- We are already using 20 gage
- TDC/TDF = "G" if made from 20 gage
- Short side does not require any additional reinforcement



Solution to Example 3

- The duct will be fabricated from 20 gage
- Use TDC/TDF
- The 36" side will have 1x1x1/8 angle on either side of the joint
 - 4 per piece of duct 2 on the "top" 2 on the "bottom"
 - No ties required (negative pressure)
- The 30" side does not require any further reinforcement.



HVAC DCS 102 Topics

- Tie Rod options
 - Positive and negative pressure
- Gage/Tie Rod relationship
- The “New” tables for TDC-TDF
- Convert from steel to aluminum
- Large rectangular duct (over 120”)



Thank You

Questions?

www.smacna.org