



# **SMACNA Seismic Restraint Manual**

**Mark Terzigni  
Project Manager  
SMACNA  
Technical  
Resources**

January 2010

## **History**

- **1976 – Guidelines for Seismic Restraint of Mechanical Systems**  
(Sheet Metal Industry Fund of Los Angeles)
- **1982 – Guidelines for Seismic Restraints of Mechanical Systems and Plumbing Piping Systems**  
(Sheet Metal Industry Fund of Los Angeles and The Plumbing and Piping Industry Council , Inc.)



## History

- **1991 – Seismic Restraint Manual – Guidelines for Mechanical Systems (SMACNA)**
  - Included larger ducts
  - Included conduit
  - Created Seismic Hazard Level (SHL)
- **1993 – Appendix E**
  - Corrections and Clarifications
  - Specific Requirements for OSHPD
  - OSHPD Approval



## History

- **1998 – Second Edition**
  - 2000 – ANSI Approval
  - 2000 – Addendum #1
    - » Changes in the 1997 UBC
    - » Brought about SHL AA



## Poll Question #1

- Which best describes your experience with projects requiring Seismic Bracing?
  - The vast majority or all of our projects require seismic bracing (80%+).
  - Most of our projects require seismic bracing (60%-80%).
  - About half of our projects require seismic bracing (40%-60%).
  - Most of our projects do **not** require seismic bracing (20%-40%).
  - Only “special” projects require seismic bracing (20% or less)
  - We have never done a project that requires seismic bracing.

## PHYSICS

$$F = Ma$$



## Older Codes

BOCA

$$F_p = A_V C_C P a_C W_C$$

SBCCI

$$F_p = A_V C_C P a_C W_C$$

ICBO

$$F_p = Z I_p C_p W_p$$

UBC 1997

$$F_p = \frac{a_p C_a I_p}{R_p} \left( 1 + 3 \frac{h_x}{h_r} \right) W_p$$



## Current Codes

International Building Code (IBC) 2006 & 2009

$$F_p = \frac{0.4 a_p S_{DS} W_p}{\left( \frac{R_p}{I_p} \right)} \left( 1 + 2 \frac{z}{h} \right)$$



## All Codes Take the Form of

$$F_p = C_s W_p$$

Where  $C_s$  = a series of variables given in the building code

$C_s$  is a measure of acceleration



## The Form is the Same

$$F_p = \frac{0.4 a_p S_{DS}}{\left( \frac{R_p}{I_p} \right)} W_p \left( 1 + 2 \frac{z}{h} \right)$$

The portion in the green box is  $C_s$



## Simplifying

$$F_p = C_s W_p \left( 1 + 2 \frac{z}{h} \right)$$



## The Components

$$\left( 1 + 2 \frac{z}{h} \right)$$

Is an adjustment for the anticipated force levels dependant on the location in the building (height)



## Basic Equation

$$F_p = C_s W_p$$

Where  $C_s$  includes the location adjustment factors



## Rearranging the Equation

$$\frac{F_p}{W_p} = C_s$$



**The SMACNA Seismic Restraint  
Manual has tables for four values  
of  $C_s$**

**These tables are identified as  
Seismic Hazard Level (SHL)**



## **SMACNA SHL Values**

$$\text{SHL A} = C_s = 1.0$$

$$\text{SHL B} = C_s = 0.75$$

$$\text{SHL C} = C_s = 0.50$$

$$\text{SHL D} = C_s = 0.25$$

These values differ from previous editions!





## Responsibilities of the Design Professional

1. Calculate  $C_s$  from the information in the applicable local building code
2. Calculate the values of  $C_s$  at the various attachment locations in the building
3. Indicate the required SMACNA SHL tables to be used at the different attachment locations



## ASCE-7 05

$$F_p = \frac{0.4a_p S_{DS} W_p}{\left( \frac{R_p}{I_p} \right)} \left( 1 + 2 \frac{z}{h} \right)$$



## ASCE-7 05 Terms

$$F_p = \frac{0.4a_p S_{DS} W_p}{\left(\frac{R_p}{I_p}\right)} \left(1 + 2\frac{z}{h}\right)$$

$F_p$  is the seismic design force



## ASCE-7 05 Terms

$$F_p = \frac{0.4a_p S_{DS} W_p}{\left(\frac{R_p}{I_p}\right)} \left(1 + 2\frac{z}{h}\right)$$

$a_p$  is the component amplification factor that varies from 1.00 to 2.50 (select from table 13.5-1 or 13.6-1)

*Table 13.6-1 contains duct and piping*



## ASCE-7 05 Terms

**TABLE 13.6-1 SEISMIC COEFFICIENTS FOR MECHANICAL AND ELECTRICAL COMPONENTS**

MECHANICAL AND ELECTRICAL COMPONENTS	$a_p^a$	$R_p^b$
Air-side HVAC, fans, air handlers, air conditioning units, cabinet heaters, air distribution boxes, and other mechanical components constructed of sheet metal framing.	2.5	6.0
Wet-side HVAC, boilers, furnaces, atmospheric tanks and bins, chillers, water heaters, heat exchangers, evaporators, air separators, manufacturing or process equipment, and other mechanical components constructed of high-deformability materials.	1.0	2.5
Engines, turbines, pumps, compressors, and pressure vessels not supported on skirts and not within the scope of Chapter 15.	1.0	2.5
Skirt-supported pressure vessels not within the scope of Chapter 15.	2.5	2.5
Elevator and escalator components.	1.0	2.5
Generators, batteries, inverters, motors, transformers, and other electrical components constructed of high deformability materials.	1.0	2.5
Motor control centers, panel boards, switch gear, instrumentation cabinets, and other components constructed of sheet metal framing.	2.5	6.0
Communication equipment, computers, instrumentation, and controls.	1.0	2.5
Roof-mounted chimneys, stacks, cooling and electrical towers laterally braced below their center of mass.	2.5	3.0
Roof-mounted chimneys, stacks, cooling and electrical towers laterally braced above their center of mass.	1.0	2.5
Lighting fixtures.	1.0	1.5
Other mechanical or electrical components.	1.0	1.5
<b>VIBRATION ISOLATED COMPONENTS AND SYSTEMS<sup>c</sup></b>		
Components and systems isolated using neoprene elements and neoprene isolated floors with built-in or separate elastomeric snubbing devices or resilient perimeter stops.	2.5	2.5
Spring isolated components and systems and vibration isolated floors closely restrained using built-in or separate elastomeric snubbing devices or resilient perimeter stops.	2.5	2.0
Internally isolated components and systems.	2.5	2.0
Supported vibration isolated equipment including its ductwork and associated internal ductwork components.	2.5	2.5
<b>DISTRIBUTION SYSTEMS</b>		
Piping in accordance with ASME B31, including in-line components with joints made by welding or brazing.	2.5	12.0
Piping in accordance with ASME B31, including in-line components, constructed of high or limited deformability materials, with joints made by threading, bonding, compression couplings, or grooved couplings.	2.5	6.0
Piping and tubing not in accordance with ASME B31, including in-line components, constructed of high-deformability materials, with joints made by welding or brazing.	2.5	9.0
Piping and tubing not in accordance with ASME B31, including in-line components, constructed of high- or limited-deformability materials, with joints made by threading, bonding, compression couplings, or grooved couplings.	2.5	4.5
Piping and tubing constructed of low-deformability materials, such as cast iron, glass, and nonconductive plastics.	2.5	3.0
Ductwork, including in-line components, constructed of high-deformability materials, with joints made by welding or brazing.	2.5	9.0
Ductwork, including in-line components, constructed of high- or limited-deformability materials with joints made by means other than welding or brazing.	2.5	6.0
Ductwork, including in-line components, constructed of low-deformability materials, such as cast iron, glass, and nonconductive plastics.	2.5	3.0
Electrical conduit, bus ducts, rigidly mounted cable trays, and plumbing.	1.0	2.5
Manufacturing or process conveyors (nonpersonnel).	2.5	3.0
Suspended cable trays.	2.5	6.0

<sup>a</sup> Lower values for  $a_p$  is permitted where justified by detailed dynamic analyses. The value for  $a_p$  shall not be less than 1.0. The value of  $a_p$  equal to 1.0 is for rigid components and rigidly attached components. The value of  $a_p$  equal to 2.5 is for flexible components and flexibly attached components.  
<sup>b</sup> Components mounted on vibration isolators shall have a bumper restraint or snubber in each horizontal direction. The design force shall be taken as  $2F_p$  if the nominal clearance (air gap) between the equipment support frame and restraint is greater than 0.25 in. If the nominal clearance specified on the construction documents is not greater than 0.25 in., the design force is permitted to be taken as  $F_p$ .

## ASCE-7 05 Terms

<b>DISTRIBUTION SYSTEMS</b>		
Piping in accordance with ASME B31, including in-line components with joints made by welding or brazing.	2.5	12.0
Piping in accordance with ASME B31, including in-line components, constructed of high or limited deformability materials, with joints made by threading, bonding, compression couplings, or grooved couplings.	2.5	6.0
Piping and tubing not in accordance with ASME B31, including in-line components, constructed of high-deformability materials, with joints made by welding or brazing.	2.5	9.0
Piping and tubing not in accordance with ASME B31, including in-line components, constructed of high- or limited-deformability materials, with joints made by threading, bonding, compression couplings, or grooved couplings.	2.5	4.5
Piping and tubing constructed of low-deformability materials, such as cast iron, glass, and nonconductive plastics.	2.5	3.0
Ductwork, including in-line components, constructed of high- or limited-deformability materials with joints made by means other than welding or brazing.	2.5	6.0
Ductwork, including in-line components, constructed of low-deformability materials, such as cast iron, glass, and nonconductive plastics.	2.5	3.0
Electrical conduit, bus ducts, rigidly mounted cable trays, and plumbing.	1.0	2.5
Manufacturing or process conveyors (nonpersonnel).	2.5	3.0
Suspended cable trays.	2.5	6.0

Typically ductwork will have  $a_p = 2.5$  and  $R_p = 6.0$

## ASCE-7 05 Terms

$$F_p = 0.4a_p S_{DS} W_p \left(1 + 2 \frac{z}{h}\right) \left(\frac{R_p}{I_p}\right)$$

$S_{DS}$  is the spectral acceleration, short period, as determined from Section 11.4.4

*Based on the soil type (site class) and the maximum considered earthquake motion for 0.2 sec (the "contour maps")*



## ASCE-7 05 Terms

$$F_p = 0.4a_p S_{DS} W_p \left(1 + 2 \frac{z}{h}\right) \left(\frac{R_p}{I_p}\right)$$

$W_p$  is the component operating weight

*When using the SMACNA seismic restraint manual be sure not to exceed the max wt. per linear ft.*



## ASCE-7 05 Terms

$$F_p = \frac{0.4a_p S_{DS} W_p}{\left( \frac{R_p}{I_p} \right) \left( 1 + 2 \frac{z}{h} \right)}$$

$R_p$  is the component response modification factor that varies from 1.00 to 12 (Select the appropriate value from Table 13.5-1 or 13.6-1) *Duct and piping are in 13.6-1*



## ASCE-7 05 Terms

$$F_p = \frac{0.4a_p S_{DS} W_p}{\left( \frac{R_p}{I_p} \right) \left( 1 + 2 \frac{z}{h} \right)}$$

$z$  is the height in structure of point of attachment of component with respect to the base. For items at or below the base  $z$  shall be taken as 0. The value  $z/h$  need not exceed 1.0

$h$  is the average roof height of structure with respect to the base



## ASCE-7 05 Terms

$$F_p = \frac{0.4a_p S_{DS} W_p}{\left( \frac{R_p}{I_p} \right)} \left( 1 + 2 \frac{z}{h} \right)$$

$I_p$  is the component importance factor that varies from 1.0 to 1.5 (see Section 13.1.3)



## Component Importance Factor

- $I_p = 1.5$  if any of the following apply:
  - The component is required to function for life-safety purposes after an earthquake, including fire protection sprinkler systems (sprinkler systems are *not covered in SMACNA's seismic restraint manual*)
  - The component contains hazardous materials
  - The component is in or attached to an Occupancy Category IV structure and it is needed for continued operation of the facility or its failure could impair the continued operation of the facility



## Component Importance Factor

- $I_p = 1.0$  for all other components
- **DO NOT CONFUSE THIS WITH THE IMPORTANCE FACTOR I FOUND IN SECTION 11.5 OF ASCE 7-05 (for the structure itself)**



## Occupancy Category

- **Occupancy category is defined in Table 1-1 in ASCE7-05.**
- **The values go from I to IV**



**Table 1-1 Occupancy Category**

**TABLE 1-1 OCCUPANCY CATEGORY OF BUILDINGS AND OTHER STRUCTURES FOR FLOOD, WIND, SNOW, EARTHQUAKE, AND ICE LOADS**

Nature of Occupancy	Occupancy Category
<p>Buildings and other structures that represent a low hazard to human life in the event of failure, including, but not limited to:</p> <ul style="list-style-type: none"> <li>• Agricultural facilities</li> <li>• Certain temporary facilities</li> <li>• Minor storage facilities</li> </ul>	I
<p>All buildings and other structures except those listed in Occupancy Categories I, III, and IV</p>	II
<p>Buildings and other structures that represent a substantial hazard to human life in the event of failure, including, but not limited to:</p> <ul style="list-style-type: none"> <li>• Buildings and other structures where more than 300 people congregate in one area</li> <li>• Buildings and other structures with daycare facilities with a capacity greater than 150</li> <li>• Buildings and other structures with elementary school or secondary school facilities with a capacity greater than 250</li> <li>• Buildings and other structures with a capacity greater than 500 for colleges or adult education facilities</li> <li>• Health care facilities with a capacity of 50 or more resident patients, but not having surgery or emergency treatment facilities</li> <li>• Jails and detention facilities</li> </ul> <p>Buildings and other structures, not included in Occupancy Category IV, with potential to cause a substantial economic impact and/or mass disruption of day-to-day civilian life in the event of failure, including, but not limited to:</p> <ul style="list-style-type: none"> <li>• Power generating stations<sup>a</sup></li> <li>• Water treatment facilities</li> <li>• Sewage treatment facilities</li> <li>• Telecommunication centers</li> </ul> <p>Buildings and other structures not included in Occupancy Category IV (including, but not limited to, facilities that manufacture, process, handle, store, use, or dispose of such substances as hazardous fuels, hazardous chemicals, hazardous waste, or explosives) containing sufficient quantities of toxic or explosive substances to be dangerous to the public if released.</p> <p>Buildings and other structures containing toxic or explosive substances shall be eligible for classification as Occupancy Category II structures if it can be demonstrated to the satisfaction of the authority having jurisdiction by a hazard assessment as described in Section 1.5.2 that a release of the toxic or explosive substances does not pose a threat to the public.</p>	III

**Table 1-1 Occupancy Category**

<p>Buildings and other structures designated as essential facilities, including, but not limited to:</p> <ul style="list-style-type: none"> <li>• Hospitals and other health care facilities having surgery or emergency treatment facilities</li> <li>• Fire, rescue, ambulance, and police stations and emergency vehicle garages</li> <li>• Designated earthquake, hurricane, or other emergency shelters</li> <li>• Designated emergency preparedness, communication, and operation centers and other facilities required for emergency response</li> <li>• Power generating stations and other public utility facilities required in an emergency</li> <li>• Ancillary structures (including, but not limited to, communication towers, fuel storage tanks, cooling towers, electrical substation<sup>1</sup> structures, fire water storage tanks or other structures housing or supporting water, or other fire-suppression material or equipment) required for operation of Occupancy Category IV structures during an emergency</li> <li>• Aviation control towers, air traffic control centers, and emergency aircraft hangars</li> <li>• Water storage facilities and pump structures required to maintain water pressure for fire suppression</li> <li>• Buildings and other structures having critical national defense functions</li> </ul> <p>Buildings and other structures (including, but not limited to, facilities that manufacture, process, handle, store, use, or dispose of such substances as hazardous fuels, hazardous chemicals, or hazardous waste) containing highly toxic substances where the quantity of the material exceeds a threshold quantity established by the authority having jurisdiction.</p> <p>Buildings and other structures containing highly toxic substances shall be eligible for classification as Occupancy Category II structures if it can be demonstrated to the satisfaction of the authority having jurisdiction by a hazard assessment as described in Section 1.5.2 that a release of the highly toxic substances does not pose a threat to the public. This reduced classification shall not be permitted if the buildings or other structures also function as essential facilities.</p>	IV
--	----

<sup>a</sup>Cogeneration power plants that do not supply power on the national grid shall be designated Occupancy Category II.



## Seismic Design Category

- **Section 11.6 in ASCE 7-05**
  - Occupancy Category I, II, or III where  $S_1 \geq 0.75$  shall be Seismic Design Category E
  - Occupancy Category IV where  $S_1 \geq 0.75$  shall be Seismic Design Category F



## Seismic Design Category

- **Section 11.6 in ASCE 7-05**
  - Otherwise pick the more severe option from Tables 11.6-1 or 11.6-2
  - Other exceptions and conditions exist consult ASCE7-05 sections 11.6 and 11.7 for specifics



Table 11.6-1 and Table 11.6-2

**TABLE 11.6-1 SEISMIC DESIGN CATEGORY BASED ON SHORT PERIOD RESPONSE ACCELERATION PARAMETER**

Value of $S_{DS}$	Occupancy Category		
	I or II	III	IV
$S_{DS} < 0.167$	A	A	A
$0.167 \leq S_{DS} < 0.33$	B	B	C
$0.33 \leq S_{DS} < 0.50$	C	C	D
$0.50 \leq S_{DS}$	D	D	D

**TABLE 11.6-2 SEISMIC DESIGN CATEGORY BASED ON 1-S PERIOD RESPONSE ACCELERATION PARAMETER**

Value of $S_{D1}$	OCCUPANCY CATEGORY		
	I or II	III	IV
$S_{D1} < 0.067$	A	A	A
$0.067 \leq S_{D1} < 0.133$	B	B	C
$0.133 \leq S_{D1} < 0.20$	C	C	D
$0.20 \leq S_{D1}$	D	D	D

## Seismic Hazard Level

- Seismic Hazard Level (SHL) is a term used in the SMACNA manual.
- $SHL = F_p/W_p$  which =  $C_s$
- SHL is the ratio of the seismic force to the item's weight.



## Terms

- **It is not necessary for the contractor to fully understand the previous terms as these values should be determined by the designer.**
- **A basic understanding of the terms will help the contractor determine when exceptions can be applied.**



## Poll Question #2

- Which best describes your typical approach to seismic bracing?
  - We have designers on staff and rarely use outside consulting.
  - We hire outside consultants for design but fabricate as much of the bracing as possible in house.
  - We go to a third party that designs and supplies most of the bracing.
  - We typically avoid projects that require seismic bracing.

## General Requirements

1. Details provide lateral bracing system. Typical vertical supports per local building code must be used.
2. Thermal expansion not given but must be considered.
3. Duct construction to conform to the appropriate SMACNA publications.



## General Requirements

4. Pipes will conform to ANSI/ASME B 31.9 Building Services Piping Code.
5. Brace in-line equipment independently of ducts and pipes.
6. Cold formed angles to conform to the requirements of the latest "Specifications for the Design of Cold-Formed Steel Structural Members" (AISI) ( $F_y = 33$  KSI)



## **General Requirements**

- 7. Hot rolled shapes and plates to conform to ASTM A36. Pipes used as braces to conform to ASTM A120 or A53.**
  
- 8. Cables to have minimum breaking strength. Per Table 3-2.**



## **General Requirements**

- 9. Bolts to conform to ASTM A307.**
- 10. Expansion anchors per Table 3-3. Proprietary connectors may be used where values are greater.**
- 11. Welding to conform to AWS D1.1 using shielded or submerged ARC method.**
- 12. Brace conduit same as equivalent weight of pipe.**



## General Requirements

13. Do not mix solid and cable bracing.
14. Bracing for equipment NOT included.
15. All runs will have a minimum of two transverse and one longitudinal braces.
16. A run is defined as any change in direction except as allowed by offsets.



## Bracing of Ducts

Seismic supports are not required for HVAC ductwork when the  $I_p = 1.0$  if either of the following conditions is met for the entire duct run:

1. Ducts are suspended from hangers 12 in. or less as measured from the top of the duct to the bottom of the support where



## Bracing of Ducts

the hanger is attached. Hangers must be positively attached to the duct within 2 in. of the top of the duct with a minimum of two #10 sheet metal screws. Lateral motion will not cause damaging impact with other systems. Lateral motion will not cause loss of vertical support.

2. Ducts have a cross-sectional area of 6 ft<sup>2</sup> or less.\*\* (less than 6 ft<sup>2</sup> per ASCE7-05)



## Code Changes

- The third edition of the Seismic Restraint Manual was written to be compliant with IBC 2006 and ASCE 7-05.
  - The CBC 2007 1614A.1.14 ASCE 7 Section 13.6.7.
    - » Modify ASCE 7 Section 13.6.7 by the following: Requirements of this section shall also apply for **Ip=1.5**
  - The IBC 2009
    - » 1613.6.8 HVAC ductwork with **Ip = 1.5**. Seismic supports are not required for HVAC ductwork with **Ip = 1.5** if either of the following conditions is met for the full length of each duct run:
      - » 1. HVAC ducts are suspended from hangers 12 inches (305 mm) or less in length with hangers detailed to avoid significant bending of the hangers and their attachments, or
      - » 2. HVAC ducts have a cross-sectional area of **less than 6** square feet (0.557 m<sup>2</sup>).
  - (expands the exceptions on previous slides)



## **Bracing of Ducts**

- 1. Transverse and longitudinal bracing per tables (Chapters 5, 6, 7 and 8).**
- 2. Ducts may be grouped. Select bracing requirements based on combined weight. Minimum of two sides to be attached to horizontal or vertical angles.**



## **Bracing of Ducts**

- 3. Wall penetrations may replace transverse brace. Solid blocking required.**





## **Bracing of Pipes or Conduit**

- 1. Brace fuel oil, and gas (such as, fuel gas, medical gas, and compressed air) as per local codes.**

- 2. Brace all pipes 3 inch nominal diameter or larger.**



## **Bracing of Pipes - Conduit**

- 3. Transverse and longitudinal bracing as per tables (Chapters 5, 6, 7 and 8).**
- 4. Provide joints/connections capable of accommodating seismic displacements where pipes pass through building seismic or expansion joints or where pipes connect to equipment with vibration isolators.**



## **Bracing of Pipes - Conduit**

- **Seismic supports are not required for piping systems where one of the following conditions is met:**
  1. **Piping is supported by rod hangers; hangers in the pipe run are 12 in. (305 mm) or less in length from the top of the pipe to the supporting structure;**



## **Bracing of Pipes - Conduit**

1. **hangers are detailed to avoid bending of the hangers and their attachments; and provisions are made for piping to accommodate expected deflections.**
2. **High-deformability piping is used; provisions are made to avoid impact with larger piping or mechanical**



## Bracing of Pipes - Conduit

2. components or to protect the piping in the event of such impact; and the following requirements are satisfied:

a) For Seismic Design Categories D, E or F where  $I_p$  is greater than 1.0, the nominal pipe size shall be 1 in. (25 mm) or less.



## Bracing of Pipes - Conduit

b) For Seismic Design Category C, where  $I_p$  is greater than 1.0, the nominal pipe size shall be 2 in. (51 mm) or less.

c) For Seismic Design Category D, E or F where  $I_p$  is equal to 1.0, the nominal pipe size shall be 3 in. (76 mm) or less.



## Bracing of Pipes - Conduit

- Ductile pipes shall be braced as outlined in the manual when using brazed or welded connections (Copper, Ductile Iron, aluminum, or steel)
- Non-ductile pipes or pipes using screw connections (cast iron, no hub, PVC) shall reduce the brace spacing by  $\frac{1}{2}$  of the spacing allowed in the manual.
- CBC 2007 allows screw connections to be in the ductile category if the piping is ductile



## CBC 2007

- 1614A.1.13 ASCE 7, Section 13.6.1.

*Modify ASCE 7 Section 13.6.1 by adding Sections 13.6.1.1 and 13.6.1.2 as follows:*

**13.6.1.1 HVAC ductwork, plumbing/piping and conduit systems. Ductwork shall be constructed in accordance with provisions contained in Part 4, Title 24, California Mechanical Code. Where possible, pipes, conduit and their connections shall be constructed of ductile materials (copper, ductile iron, steel or aluminum and **brazed, welded or screwed connections**). Pipes, conduits and their connections, constructed of non-ductile materials (e.g., cast iron, no-hub pipe and plastic), shall have the brace spacing reduced to satisfy requirements of ASCE 7 Chapter 13 and not to exceed one-half of the spacing allowed for ductile materials.**

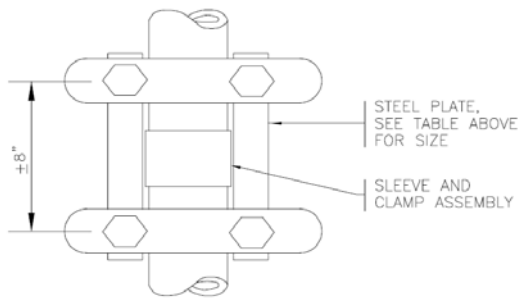
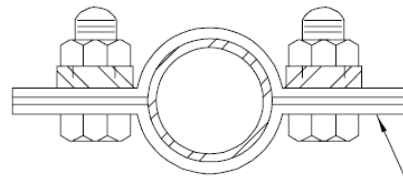


**Vertical risers not specifically  
engineered will be laterally  
supported with a riser clamp at  
each floor.**



**Figure 10-10 Riser Bracing for Hubless Pipe**

PIPE SIZE	PLATE SIZE	BOLT SIZE
UP TO 2"	1/4" X 1-1/4"	1/4"
2-1/2" TO 3"	1/4" X 1-1/4"	3/8"
4" & 5"	1/4" X 1-1/4"	1/2"
6"	3/8" X 1-1/2"	1/2"
8"	3/8" X 1-1/2"	5/8"



## DEFINITIONS

- **TRANSVERSE BRACE** - those designed and installed to restrain movement in the direction perpendicular to the piping or duct run



## DEFINITIONS

- **LONGITUDINAL BRACE** - those designed and installed to restrain movement in the direction parallel to the piping or duct run
- **RUN (Piping or Duct)** - a straight length with no changes in direction except as allowed by offsets



## Elements of a Seismic Restraint

- Brace
- Attachment to the Component
- Attachment to the Structure



## Bracing Members

### RIGID

- Angles
- Pipes
- Strut Channels

### NON-RIGID

- Cables

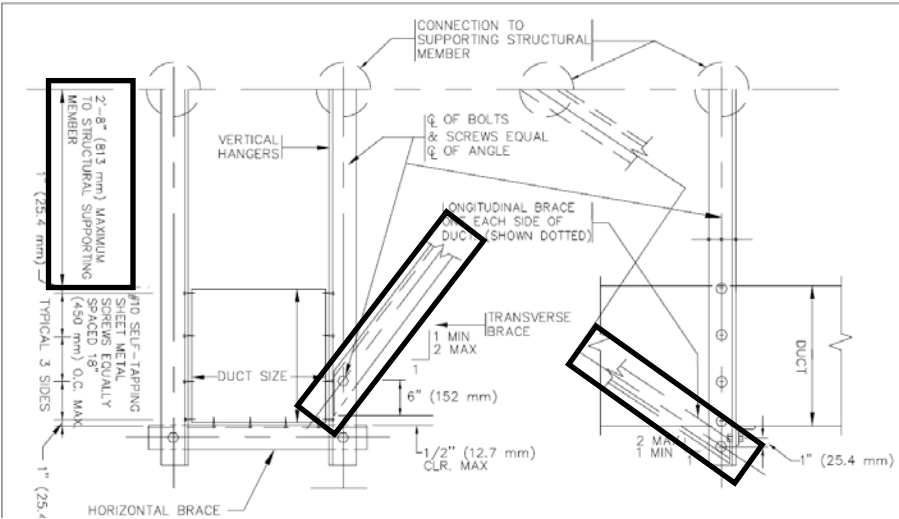


# Connections to Ducts

- The SMACNA Seismic Restraint Manual Contains 12 Different Details for Connecting to Ductwork, Rectangular and Round



FIGURE 4-2 SIDE BRACING FOR RECTANGULAR DUCTS





# Notes

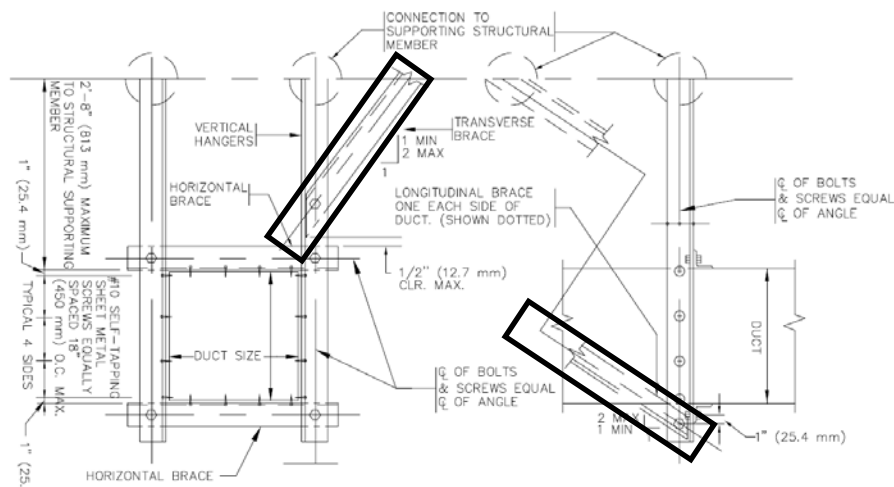
NOTES:

1. REFER TO CHAPTER 3 FOR GENERAL REQUIREMENTS.
2. WHEN A COMBINATION OF DUCTS IS USED IN LIEU OF ONE DUCT, AT LEAST 2 SIDES OF EACH DUCT MUST BE CONNECTED TO VERTICAL OR HORIZONTAL ANGLES AND THE COMBINED WEIGHT SHALL NOT EXCEED THAT GIVEN IN THE TABLE. (ADD HORIZONTAL ANGLES IF REQUIRED).
3. SEE TABLE 5-1, 6-1, 7-1, OR 8-1 FOR VERTICAL HANGERS, DIAGONAL AND HORIZONTAL BRACES, BOLT SIZE, CONNECTION TO STRUCTURAL SUPPORTING MEMBERS, AND SPACING OF BRACING.

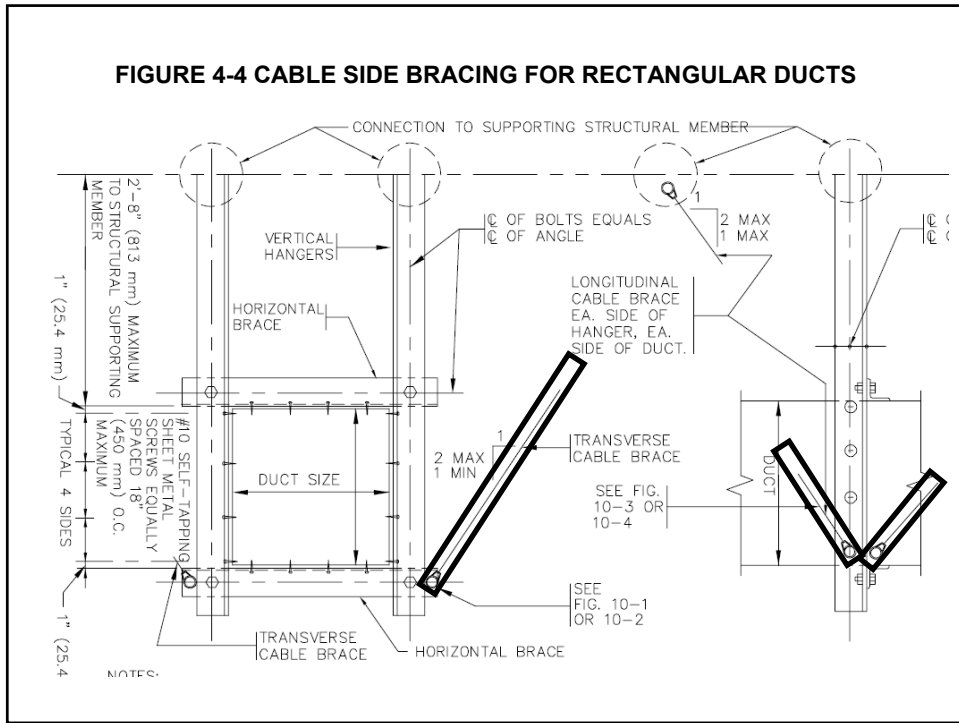
- The notes are specific to each drawing these are just a typical representation.



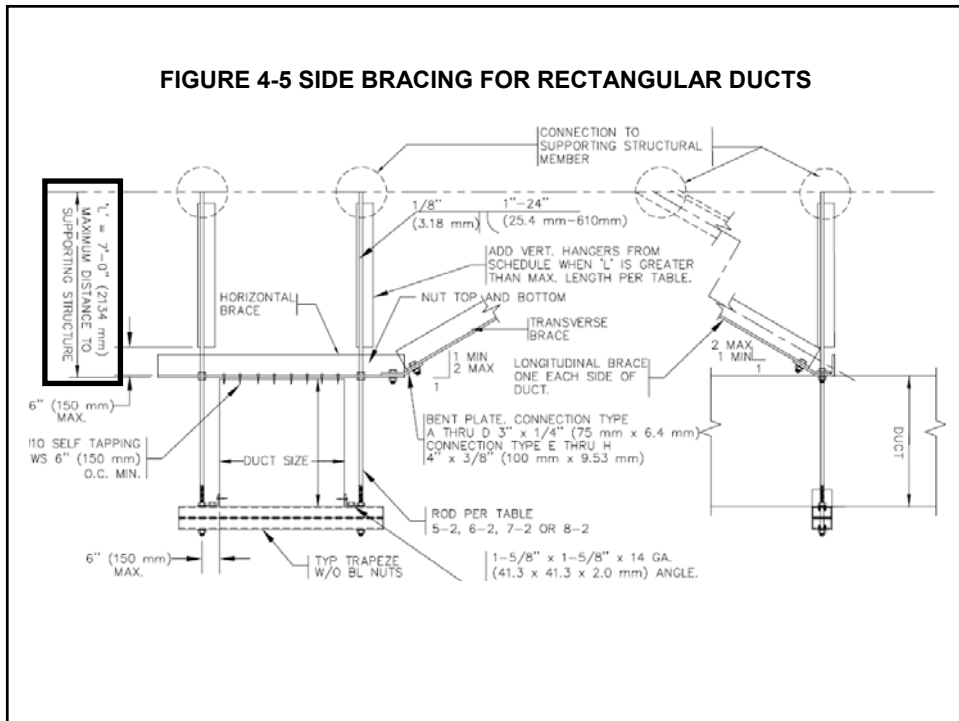
**FIGURE 4-3 SIDE BRACING FOR RECTANGULAR DUCTS**



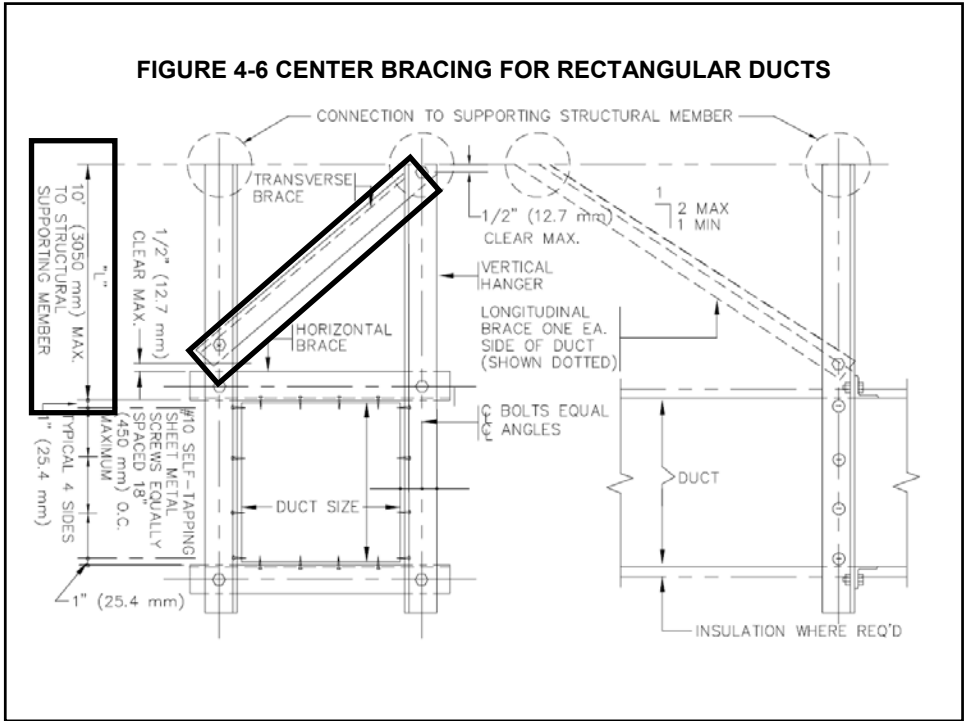
**FIGURE 4-4 CABLE SIDE BRACING FOR RECTANGULAR DUCTS**



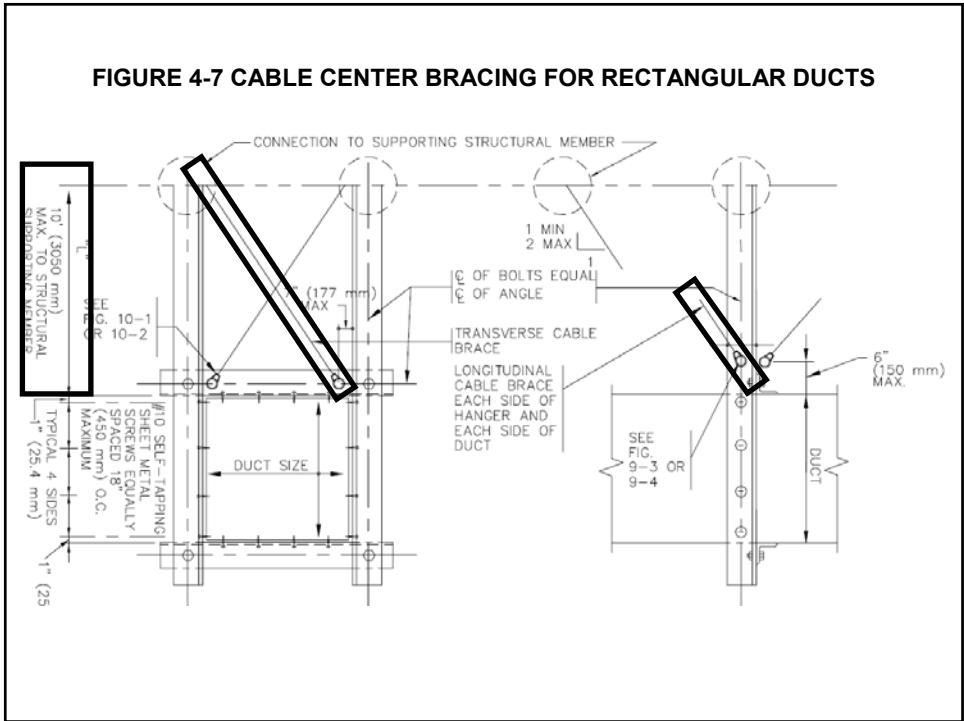
**FIGURE 4-5 SIDE BRACING FOR RECTANGULAR DUCTS**



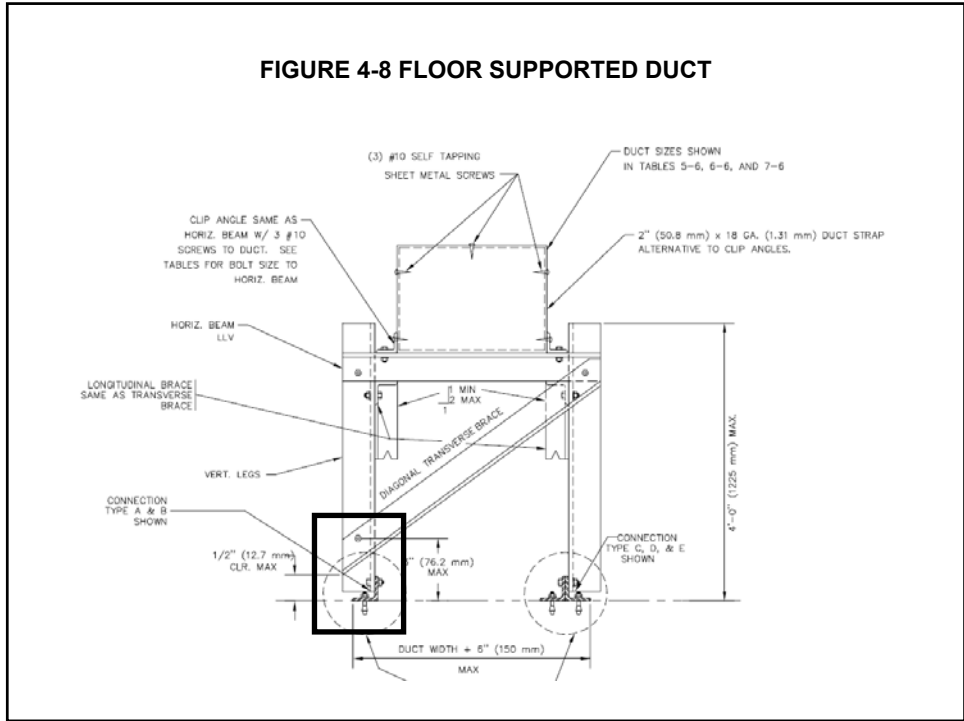
**FIGURE 4-6 CENTER BRACING FOR RECTANGULAR DUCTS**



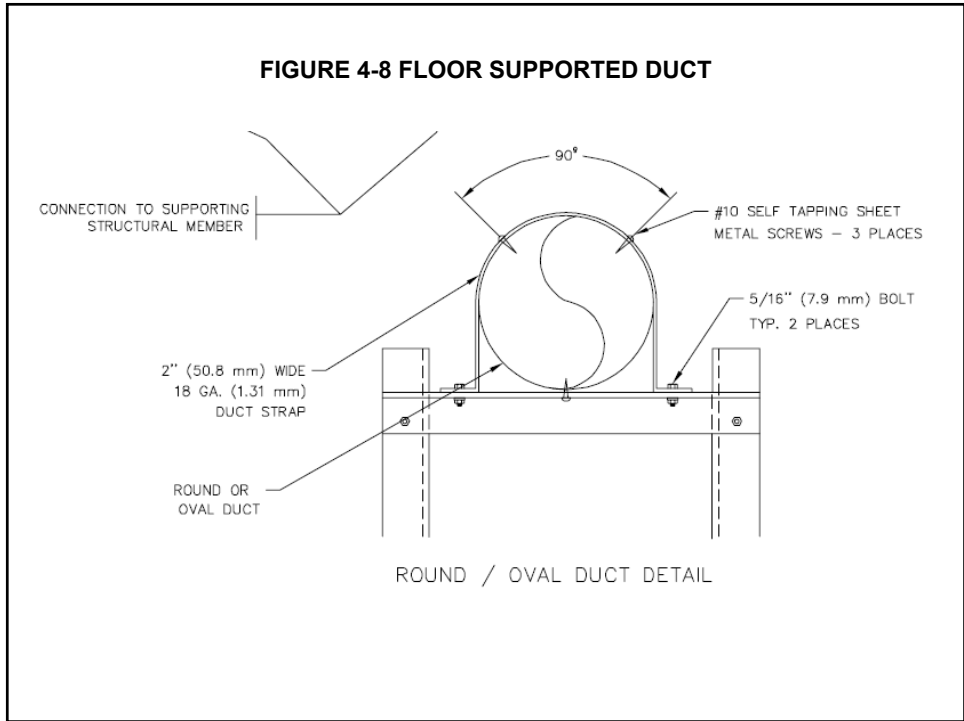
**FIGURE 4-7 CABLE CENTER BRACING FOR RECTANGULAR DUCTS**



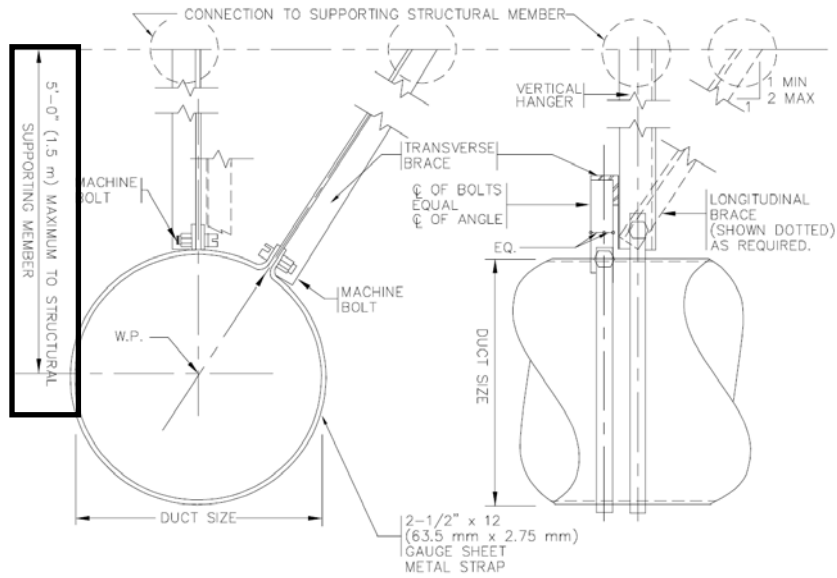
**FIGURE 4-8 FLOOR SUPPORTED DUCT**



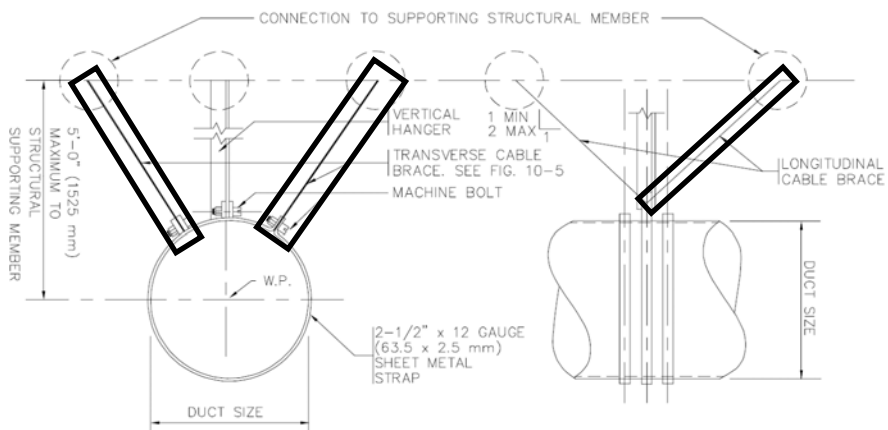
**FIGURE 4-8 FLOOR SUPPORTED DUCT**



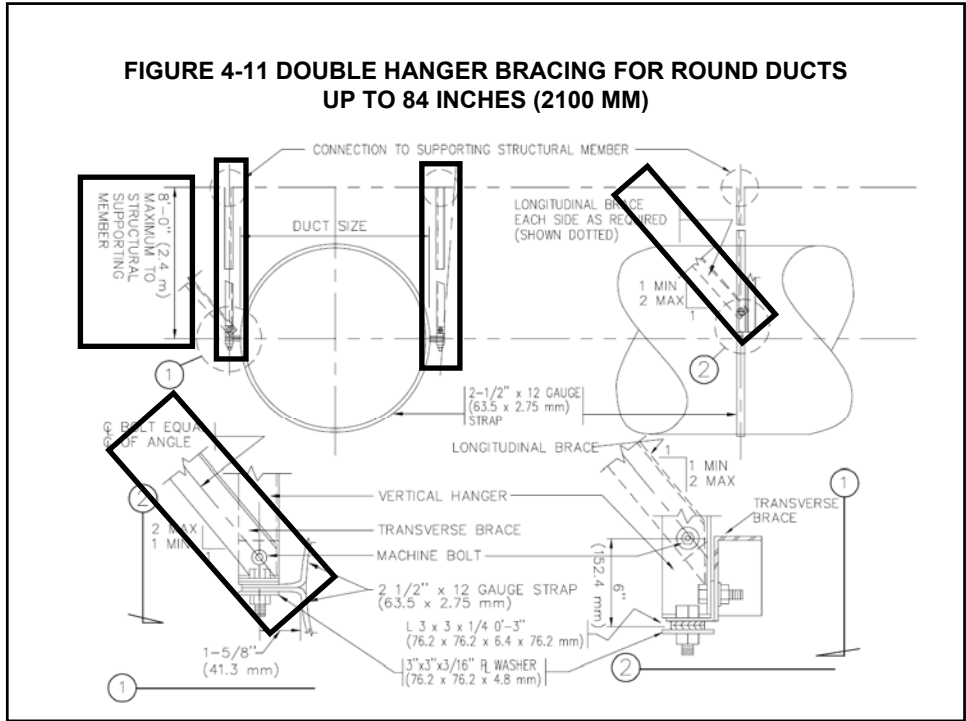
**FIGURE 4-9 SINGLE HANGER SPACING FOR ROUND DUCTS  
33-36 INCHES (838-900 MM)**



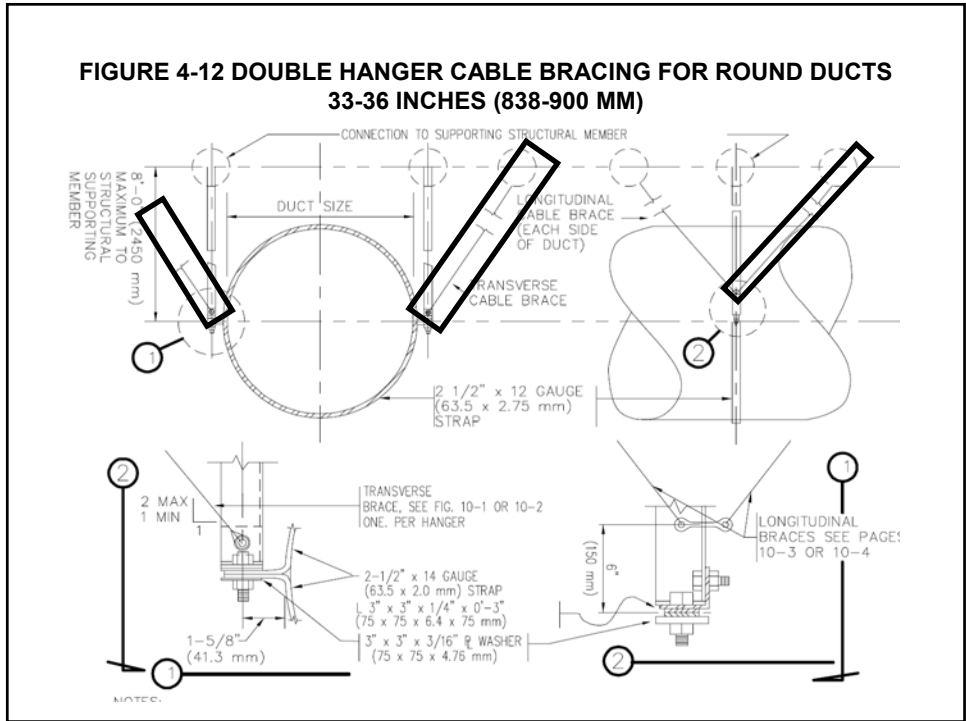
**FIGURE 4-10 SINGLE HANGER CABLE BRACING FOR ROUND DUCTS  
33-36 INCHES (838-900 MM)**



**FIGURE 4-11 DOUBLE HANGER BRACING FOR ROUND DUCTS UP TO 84 INCHES (2100 MM)**



**FIGURE 4-12 DOUBLE HANGER CABLE BRACING FOR ROUND DUCTS 33-36 INCHES (838-900 MM)**

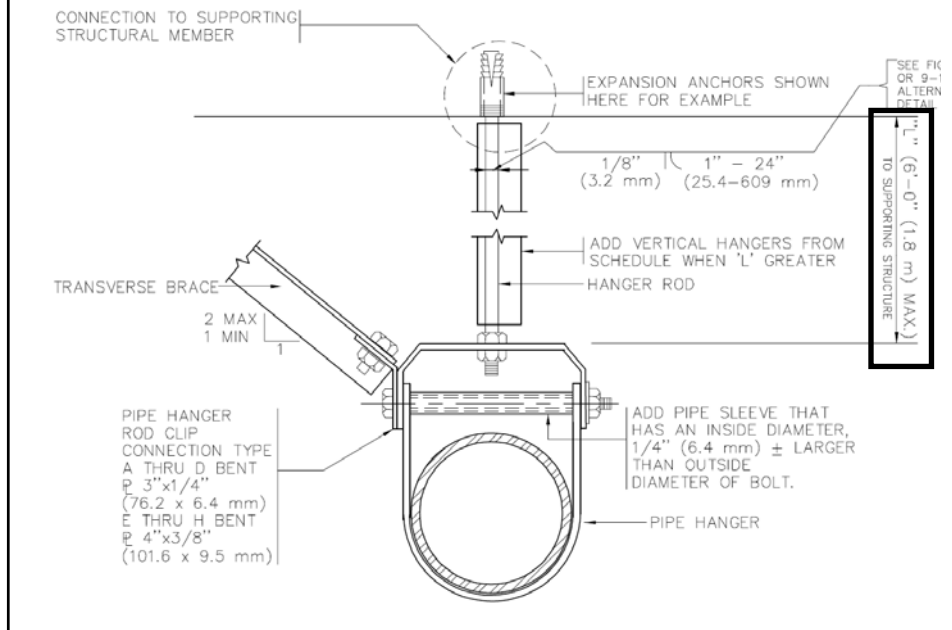


# Connections to Piping/Conduit Systems

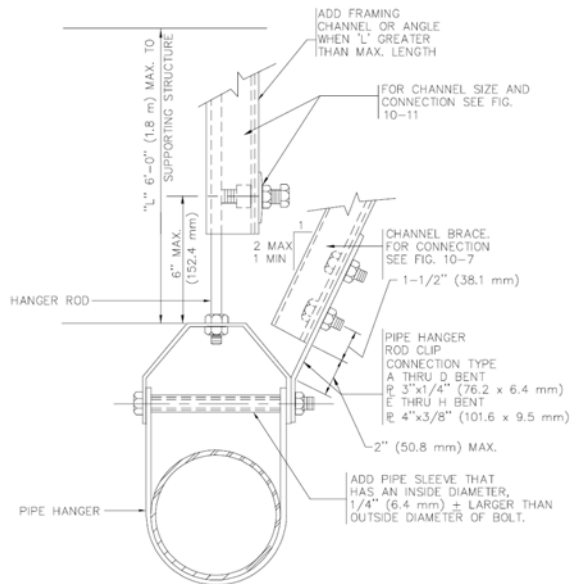
- The SMACNA Seismic Restraint Manual Contains 10 Different Details for Connecting to Piping/Conduit Systems



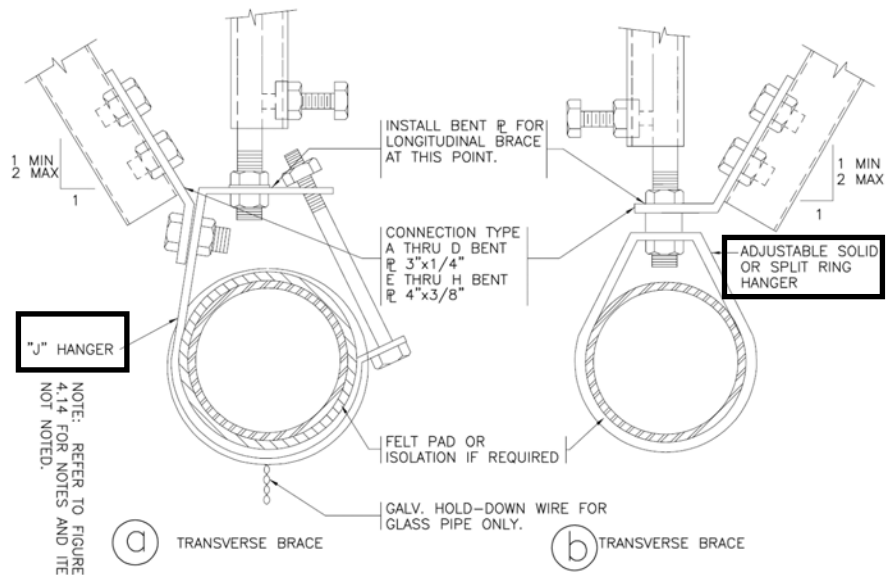
**FIGURE 4-13 TRANSVERSE BRACING FOR PIPES**



**FIGURE 4-14 TRANSVERSE STRUT BRACING FOR PIPES**

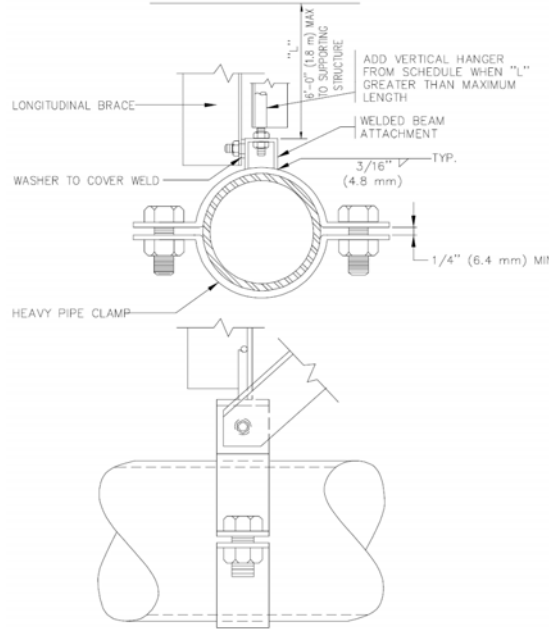


**FIGURE 4-15 ALTERNATE ATTACHMENT TO HANGER FOR PIPE BRACING**

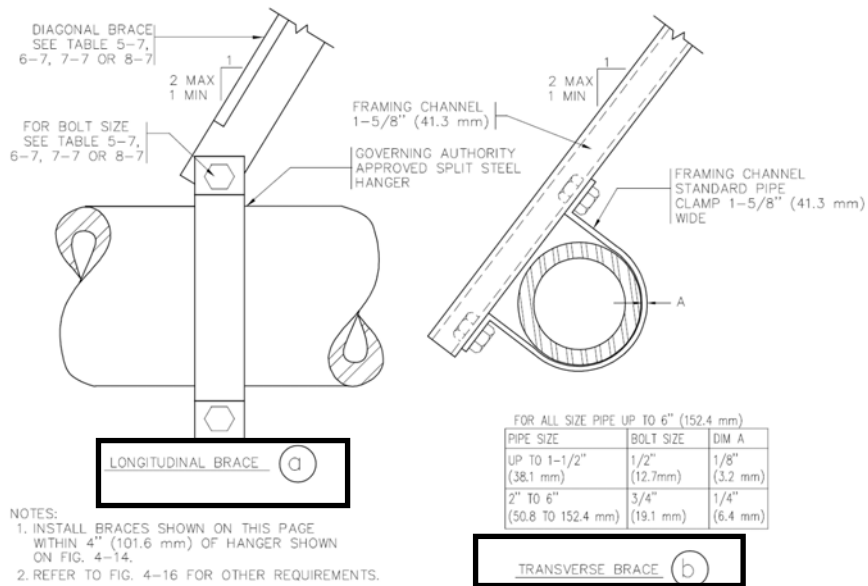




**FIGURE 4-16 LONGITUDINAL BRACING FOR PIPES**

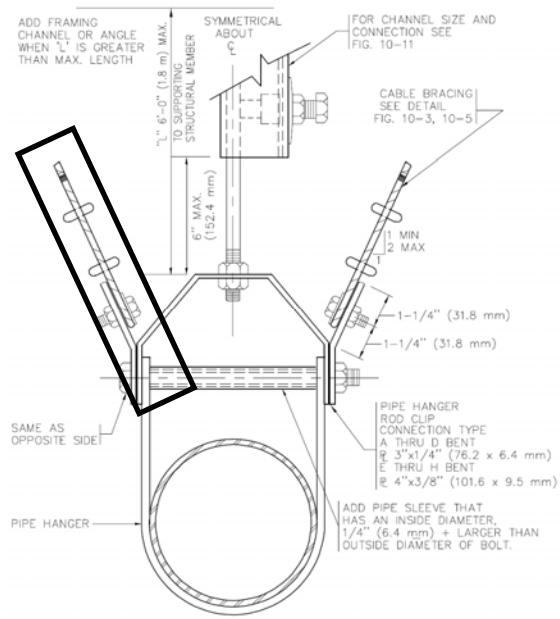


**FIGURE 4-17 ALTERNATE BRACING FOR PIPES**

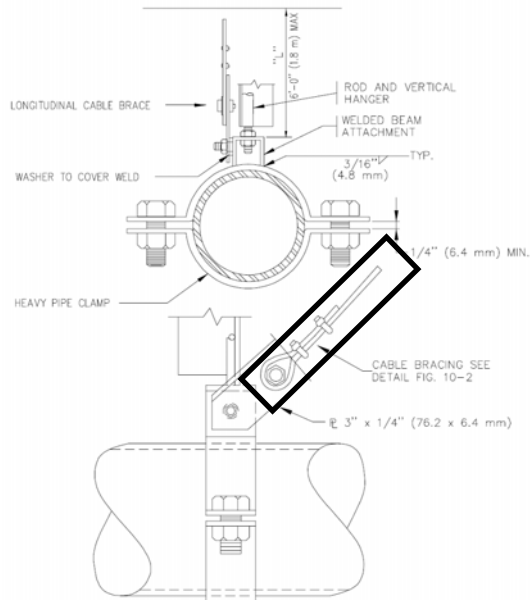


NOTES:  
1. INSTALL BRACES SHOWN ON THIS PAGE WITHIN 4" (101.6 mm) OF HANGER SHOWN ON FIG. 4-14.  
2. REFER TO FIG. 4-16 FOR OTHER REQUIREMENTS.

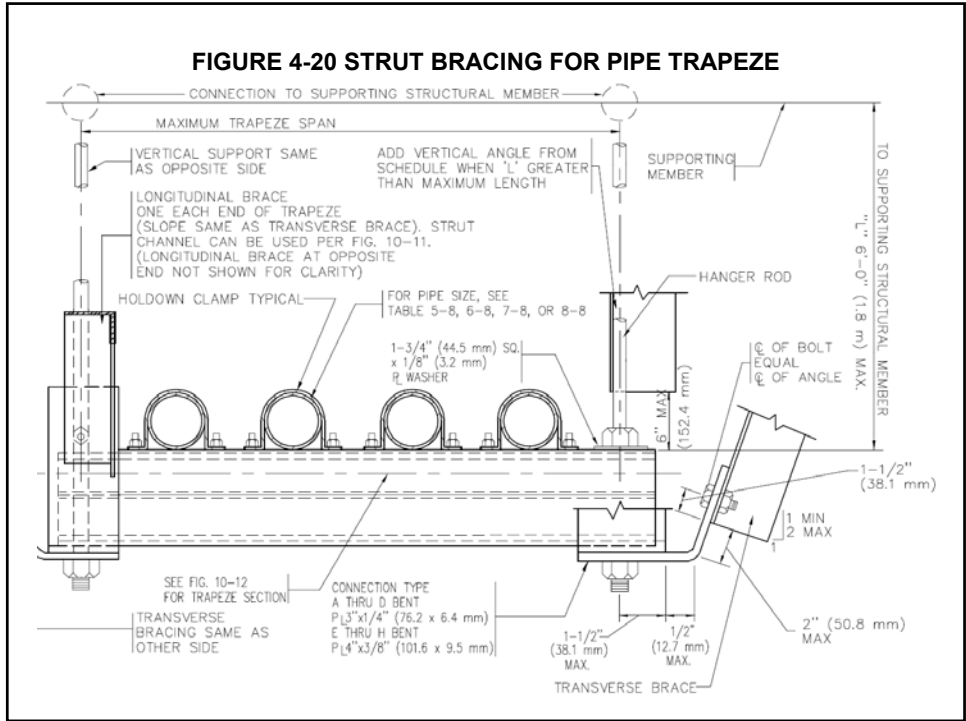
**FIGURE 4-18 TRANSVERSE CABLE BRACING FOR PIPES**



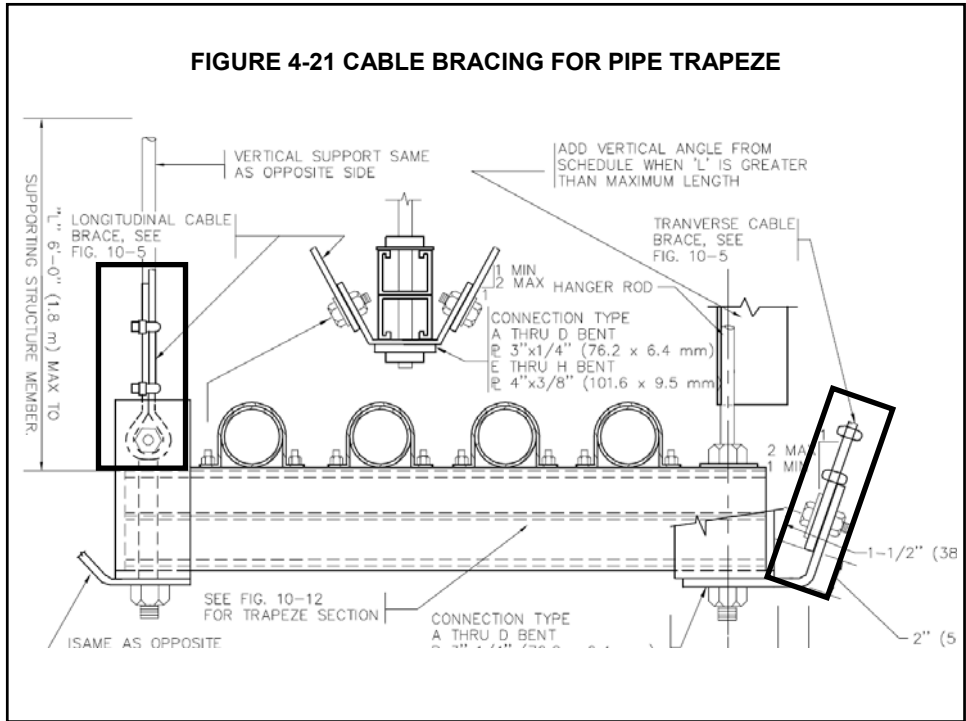
**FIGURE 4-19 LONGITUDINAL CABLE BRACING FOR PIPES**



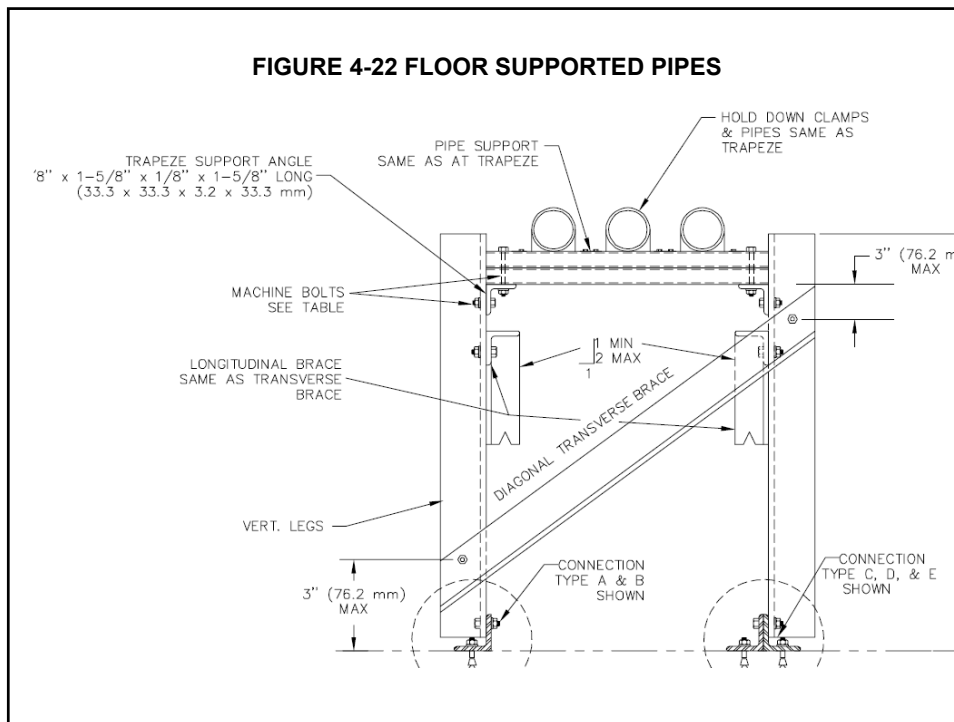
**FIGURE 4-20 STRUT BRACING FOR PIPE TRAPEZE**



**FIGURE 4-21 CABLE BRACING FOR PIPE TRAPEZE**



**FIGURE 4-22 FLOOR SUPPORTED PIPES**



## Connections to the Structure

- **The SMACNA Seismic Restraint Manual Contains 8 Levels for Connection into Concrete**
  - (2) 1 Bolt Connection**
  - (3) 2 Bolt Connections**
  - (3) 4 Bolt Connections**

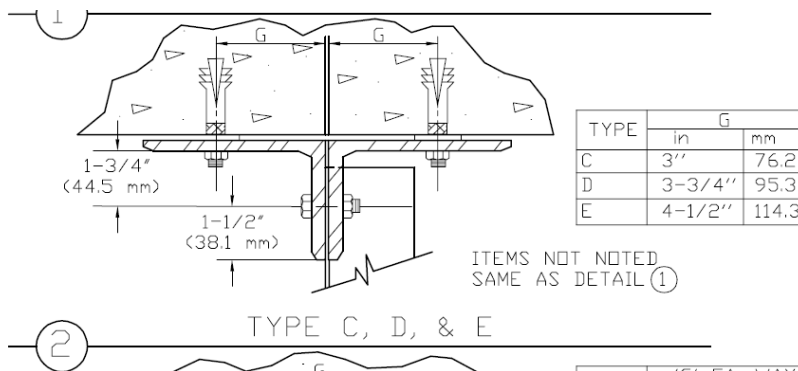


# Connections to the Structure

- The SMACNA Manual Contains
  - (6) Alternative Connections to Concrete
  - (6) Details for Connection to Steel
  - (3) Details for Connections to Wood

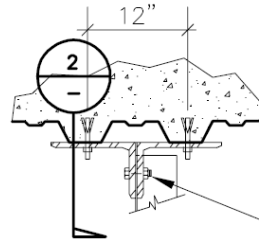


## CONNECTIONS TO STRUCTURES



### CONNECTIONS TO STRUCTURES

ITEMS NOT NOTED  
SAME AS DETAIL ①

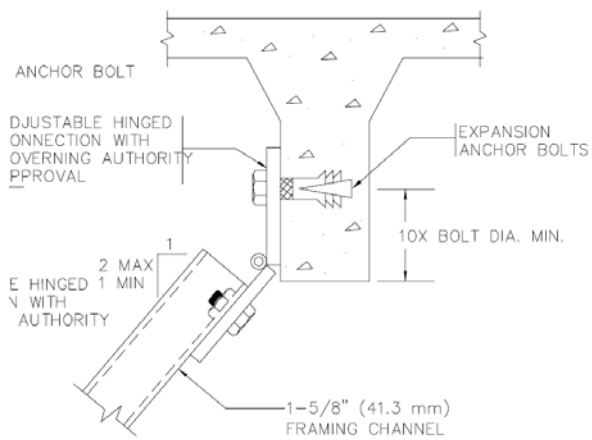


MACHINE BOLT SEE  
SCHEDULE

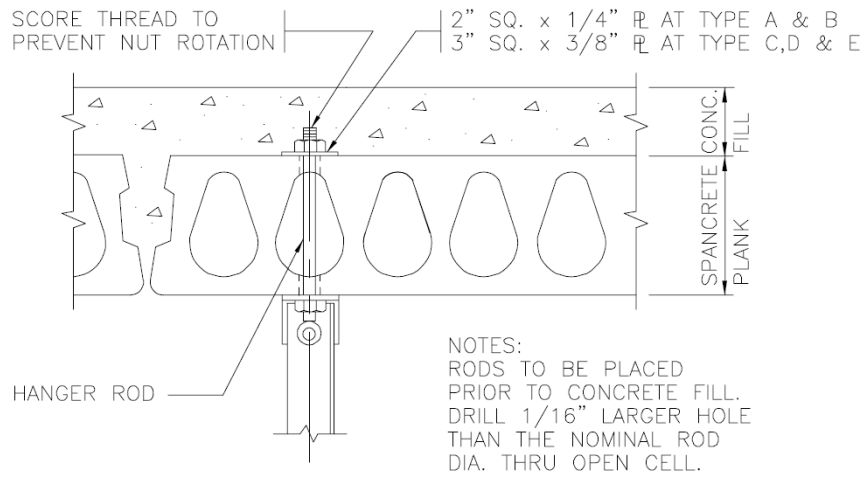
TYPE I

⑥

### CONNECTIONS TO STRUCTURES

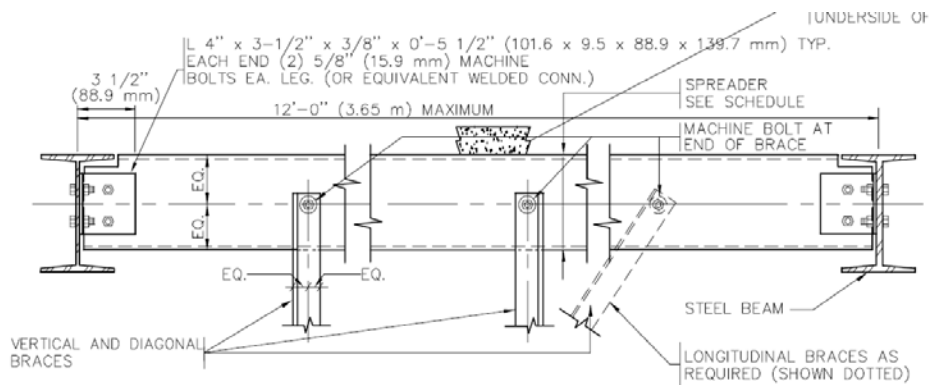


**CONNECTIONS TO STRUCTURES**

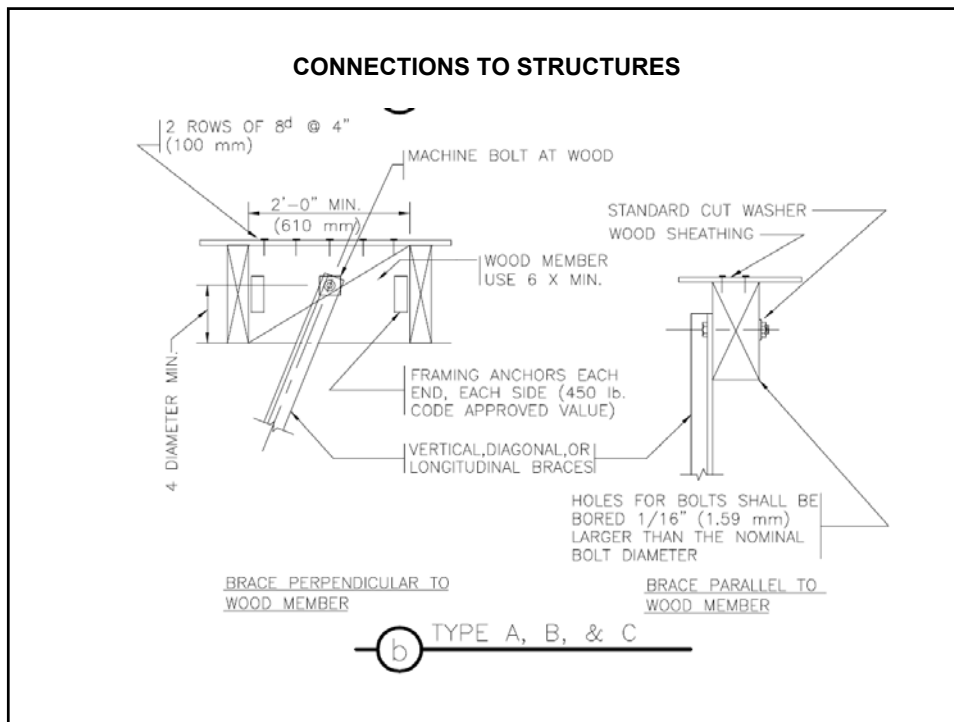


**a** CONNECTION TO HOLLOW CORE PLANK  
TYPE A, B, C, D, & E

**CONNECTIONS TO STRUCTURES**



**b** CONNECTIONS TO SPREADERS TYPE A THRU H  
USE WITH VERTICAL, DIAGONAL, AND LONGITUDINAL L'S



## Miscellaneous Connections

The SMACNA Manual contains:

- Specific Details on Various Connections
- Bracing for Hubless Cast Iron Pipe
- Riser Bracing for Hubless Pipes
- Seismic Joints in Pipes





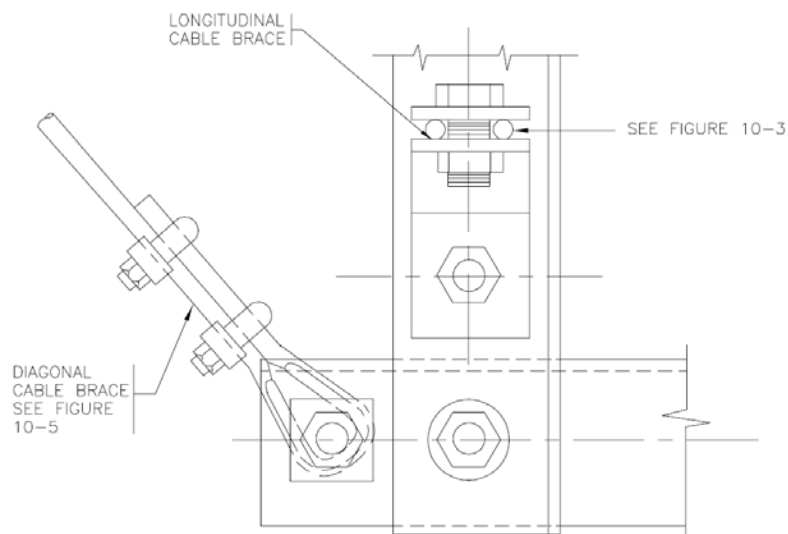
# Miscellaneous Connections

The SMACNA Manual contains:

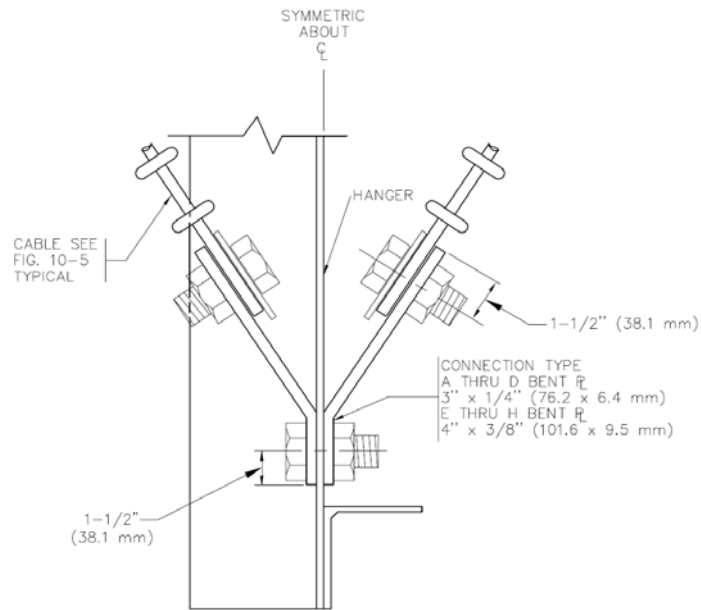
- Welded Tabs for Pipe Connections
- Stiffeners & Saddles at Pipe Clamps



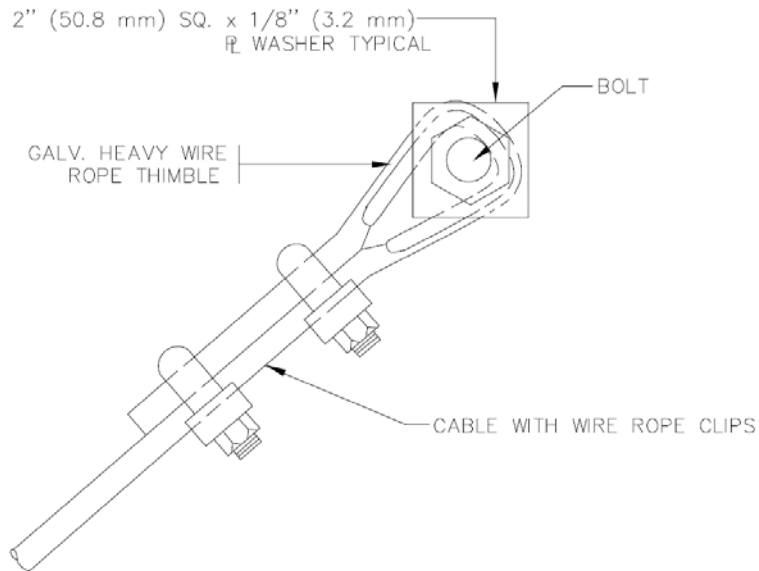
## MISCELLANEOUS CONNECTIONS



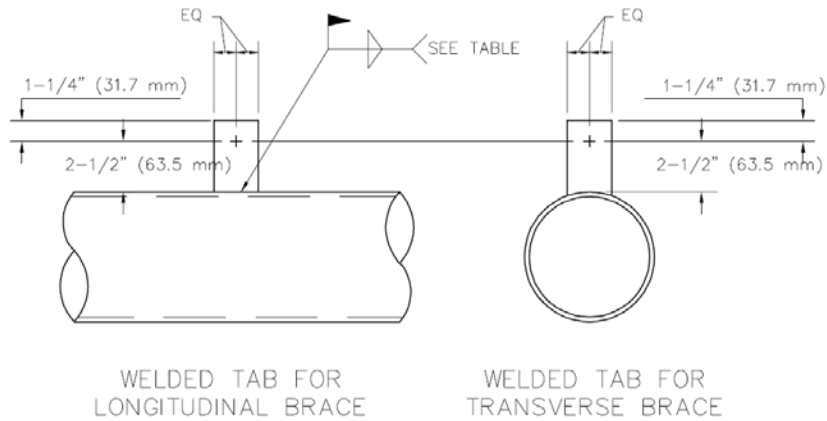
### MISCELLANEOUS CONNECTIONS



### MISCELLANEOUS CONNECTIONS



## MISCELLANEOUS CONNECTIONS



## The Ten Step Process

1. Get the SHL from the Designer
2. Check the structural system (*What the ducts and pipes hang from*)
3. Find the detail in Chapter 4 that corresponds to your condition
4. Determine which chapter has the correct schedule (based on SHL)



## **The Ten Step Process**

- 5. Find the correct table in that chapter (see notes from detail selected in chapter 4)**
- 6. Determine the proper row (size and weight)**
- 7. Use the row to get information on the sizes of hangers, bolts, etc.**



## **The Ten Step Process**

- 8. Use the row to get the connection type (A through I)**
- 9. Use Table 9-1 and connection type to determine the size and quantity of anchor, bolt, angle, etc.**
- 10. Find the detail in Chapter 9 that corresponds to the connection type and the supporting structure.**



## Example 1

- Single run of rectangular duct
- Top of duct is 5'-8" from to supporting structure
- Duct size 58" x 24" @ 36 lb/ft
- $C_s = .80$  so SHL=A **Provided by designer**

## Example 1

- First determine the applicable figures in Chapter 4.
  - Can not use Figures 4-2 thru 4-4
    - too far from the structure
  - Figures 4-5 thru 4-7 qualify
    - Note Figure 4-8 is for floor supports
  - Because of preference and jobsite conditions we will use Figure 4-7 which is for center bracing using cable

# Example 1

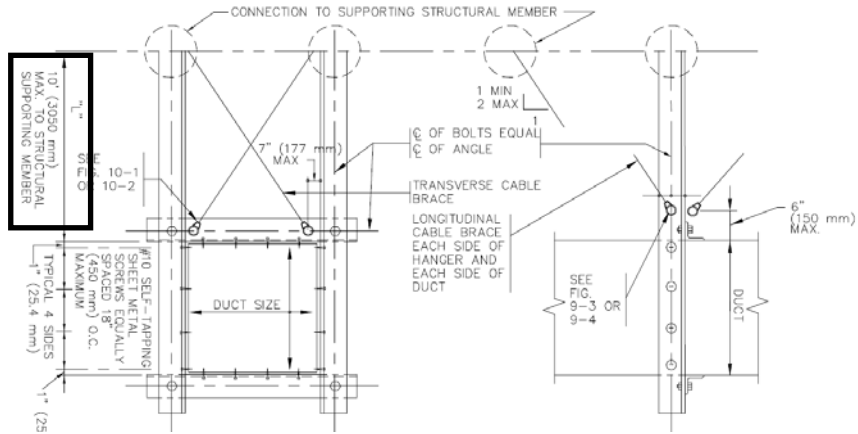


Figure 4-7

# Example 1

- Figure 4-7
  - Note 3, Since  $L = 5'-8''$  we need to use table 5-3, 6-3, 7-3, or 8-3
  - In our case  $SHL = A$  (Chapter 5)
    - Use Table 5-3 because chapter 5 is for SHL A

NOTES:

1. REFER TO CHAPTER 3 FOR GENERAL REQUIREMENTS.
2. WHEN A COMBINATION OF DUCTS IS USED IN LIEU OF ONE DUCT, AT LEAST 2 SIDES OF EACH DUCT MUST BE CONNECTED TO VERTICAL OR HORIZONTAL ANGLES AND THE COMBINED WEIGHT SHALL NOT EXCEED THAT GIVEN IN THE TABLE. (ADD HORIZONTAL ANGLES IF REQUIRED).
3. WHERE "L" IS LESS THAN 7 FEET (2134 mm), SEE TABLE 5-3, 6-3, 7-3 or 8-3; OTHERWISE SEE TABLE 5-4, 6-4, 7-4, OR 8-4 FOR VERTICAL HANGERS, DIAGONAL AND HORIZONTAL BRACES, BOLT SIZE CONNECTION TO SUPPORTING STRUCTURAL MEMBER, AND SPACING OF BRACING.

# Example 1

Duct Size WxD <sup>1</sup> (in.)	Vertical Hangers Angles (in.)	Transverse Braces Angle Pipe (Cable Size) <sup>2</sup> (in.)	Horizontal Braces Angles (in.)	Longitudinal Braces Angle (Cable Size) <sup>2</sup> (in.)	Bolt Size (in.)	Connection Type to Structural Members <sup>3</sup>	Max. Wt. Ft <sup>4</sup> (lb)
30x30	L4x4x14ga	L4x4x14ga (D)	L2x2x16ga	L4x4x14ga (C)	3/8	C	17
42x42	L4x4x14ga	L2.5x2.5x12ga (E)	L2x2x16ga	L3x3x12ga (E)	3/8	C	29
54x54	L4x4x14ga	L3x3x12ga (F)	L2x2x16ga	L4x4x12ga (F)	3/8	D	46
60x60	L4x4x14ga	L4x4x12ga (F)	L2x2x16ga	L4x4x12ga (G)	1/2	D	54
84x84	L3x3x12ga	2 1/2 Pipe (H)	L2.5x2.5x16ga	2 1/2 Pipe (I)	3/8	E	103
96x96	L3x3x12ga	2 1/2 Pipe (H)	L2.5x2.5x16ga	2 1/2 Pipe (J)	3/8	E	129
54x28	L4x4x14ga	L3x3x12ga (D)	L2x2x16ga	L3x3x12ga (E)	3/8	D	34
60x30	L4x4x14ga	L3x3x12ga (E)	L2x2x16ga	L3x3x12ga (F)	3/8	D	39
84x42	L4x4x14ga	L4x4x12ga (G)	L2.5x2.5x16ga	L4x4x12ga (H)	1/2	E	74
96x48	L4x4x14ga	2 1/2 Pipe (G)	L2.5x2.5x16ga	2 1/2 Pipe (I)	3/8	E	97
108x54	L3x3x12ga	2 1/2 Pipe (H)	L3x3x16ga	2 1/2 Pipe (J)	3/8	E	110
120x60	L3x3x12ga	2 1/2 Pipe (H)	L4x4x16ga	2 1/2 Pipe (J)	3/8	E	121

Table 5-3 Center Bracing For Rectangular Ducts, SHL A, L=7 ft

# Example 1

Duct Size WxD <sup>1</sup> (in.)	Vertical Hangers Angles (in.)	Transverse Braces Angle Pipe (Cable Size) <sup>2</sup> (in.)	Horizontal Braces Angles (in.)	Longitudinal Braces Angle (Cable Size) <sup>2</sup> (in.)	Bolt Size (in.)	Connection Type to Structural Members <sup>3</sup>	Max. Wt. Ft <sup>4</sup> (lb)
54x28	L4x4x14ga	L3x3x12ga (D)	L2x2x16ga	L3x3x12ga (E)	3/8	D	34
60x30	L4x4x14ga	L3x3x12ga (E)	L2x2x16ga	L3x3x12ga (F)	3/8	D	39

NOTES:

- The ducts' maximum dimensions will govern what bracing is required. Example: A 72 x 30 in. duct will be braced like an 84 x 42 in. duct.
- Provide transverse bracing at 30 ft and longitudinal bracing at 60 ft. See Table 3-2 for cable size.
- See Table 9-1 for "Connection Type" to structural supporting members.
- Maximum weight of duct or combinations of ducts is per linear foot. For ducts weighing more than the maximum weight per foot, use the next higher duct size.

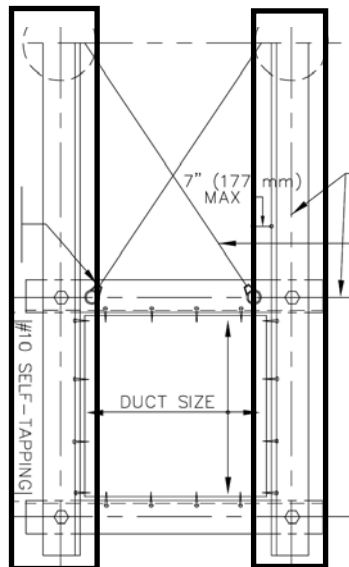
# Example 1

Duct Size W×D <sup>1</sup> (in.)	Vertical Hangers Angles (in.)	Transverse Braces Angle Pipe (Cable Size) <sup>2</sup> (in.)	Horizontal Braces Angles (in.)	Longitudinal Braces Angle (Cable Size) <sup>2</sup> (in.)	Bolt Size (in.)	Connection Type to Structural Members <sup>3</sup>	Max. Wt. Fr <sup>4</sup> (lb)
54×26	L4×4×14ga	L3×3×12ga (D)	L2×2×16ga	L3×3×12ga (E)	¾	D	34
60×30	L4×4×14ga	L3×3×12ga (E)	L2×2×16ga	L3×3×12ga (F)	¾	D	39

**NOTES:**

1. The ducts' maximum dimensions will govern what bracing is required. Example: A 72 × 30 in. duct will be braced like an 84 × 42 in. duct.
2. Provide transverse bracing at 30 ft and longitudinal bracing at 60 ft. See Table 3-2 for cable size.
3. See Table 9-1 for "Connection Type" to structural supporting members.
4. Maximum weight of duct or combinations of ducts is per linear foot. For ducts weighing more than the maximum weight per foot, use the next higher duct size.

# Example 1



- The vertical hangers are 4 x 4 x 14 gage angle



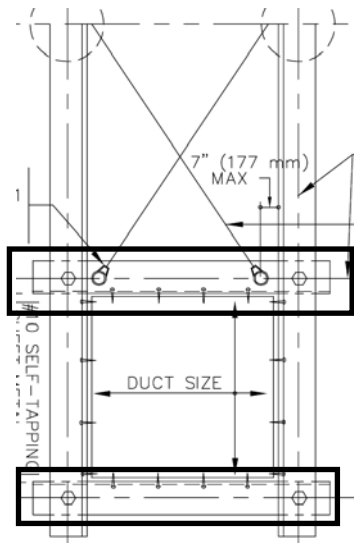
# Example 1

Duct Size W×D <sup>1</sup> (in.)	Vertical Hangers Angles (in.)	Transverse Braces Angle Pipe (Cable Size) <sup>2</sup> (in.)	Horizontal Braces Angles (in.)	Longitudinal Braces Angle (Cable Size) <sup>2</sup> (in.)	Bolt Size (in.)	Connection Type to Structural Members <sup>3</sup>	Max. Wt. Fr <sup>4</sup> (lb)
54×28	L4×4×14ga	L3×3×12ga (D)	L2×2×16ga	L3×3×12ga (E)	3/8	D	34
60×30	L4×4×14ga	L3×3×12ga (E)	L2×2×16ga	L3×3×12ga (F)	3/8	D	39

**NOTES:**

1. The ducts' maximum dimensions will govern what bracing is required. Example: A 72 × 30 in. duct will be braced like an 84 × 42 in. duct.
2. Provide transverse bracing at 30 ft and longitudinal bracing at 60 ft. See Table 3-2 for cable size.
3. See Table 9-1 for "Connection Type" to structural supporting members.
4. Maximum weight of duct or combinations of ducts is per linear foot. For ducts weighing more than the maximum weight per foot, use the next higher duct size.

# Example 1



- The horizontal braces are 2 x 2 x 16 gage angle

# Example 1

Duct Size W×D <sup>1</sup> (in.)	Vertical Hangers Angles (in.)	Transverse Braces Angle Pipe (Cable Size) <sup>2</sup> (in.)	Horizontal Braces Angles (in.)	Longitudinal Braces Angle (Cable Size) <sup>2</sup> (in.)	Bolt Size (in.)	Connection Type to Structural Members <sup>3</sup>	Max. Wt. Fr <sup>4</sup> (lb)
54×28	L4×4×14ga	L3×3×12ga (D)	L2×2×16ga	L3×3×12ga (E)	¾	D	34
60×30	L4×4×14ga	L3×3×12ga (E)	L2×2×16ga	L3×3×12ga (F)	¾	D	39

**NOTES:**

1. The ducts' maximum dimensions will govern what bracing is required. Example: A 72 × 30 in. duct will be braced like an 84 × 42 in. duct.
2. Provide transverse bracing at 30 ft and longitudinal bracing at 60 ft. See Table 3-2 for cable size.
3. See Table 9-1 for "Connection Type" to structural supporting members.
4. Maximum weight of duct or combinations of ducts is per linear foot. For ducts weighing more than the maximum weight per foot, use the next higher duct size.

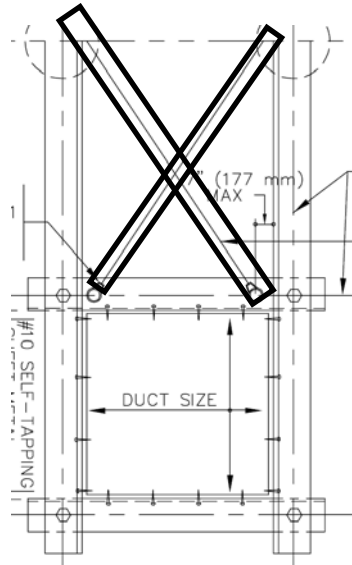
# Example 1

ID	Cable Design Strength					
	Nominal Size		Breaking Strength		Design Strength	
	in	mm	lbf	kN	lbf	kN
A	1/8	3.2	1,330	5.9	466	2.1
B	3/32	4.0	2,140	9.5	749	3.3
C	1/8	4.8	2,850	12.7	998	4.4
D	3/32	5.6	3,850	17.1	1,348	6.0
E	1/4	6.4	4,750	21.1	1,663	7.4
F	5/32	7.1	6,400	28.5	2,240	10.0
G	3/16	7.9	8,000	35.6	2,800	12.5
H	1/8	9.5	10,800	48.0	3,780	16.8
I	3/16	11.1	14,500	64.5	5,075	22.6
J	1/2	12.7	18,800	83.6	6,580	29.3
K	5/16	14.3	24,100	107.2	8,435	37.5
L	3/8	15.9	29,600	131.7	10,360	46.1
M	3/4	19.1	40,800	181.5	14,280	63.5
N	7/8	22.2	55,800	248.2	19,530	86.9
O	1	25.4	71,900	319.8	25,165	111.9

Table 3-2

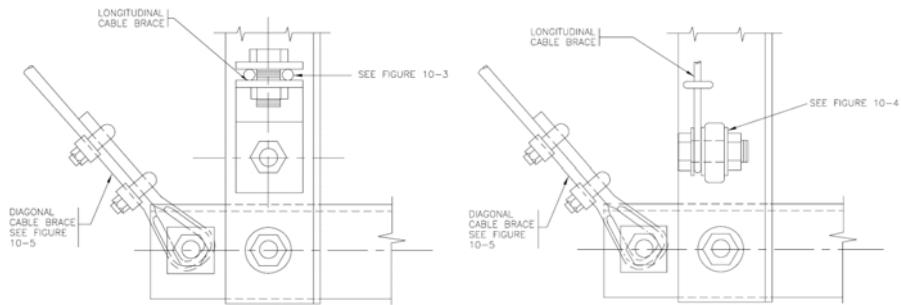
Safety factor ~ 2.85

## Example 1



- The transverse brace cables are a class E per Table 3-2 (nominal 1/4" diameter)
- The transverse brace spacing is 30 ft.

## Example 1



- Figures 10-1 and 10-2 cable connection to duct frame

# Example 1

Duct Size W×D <sup>1</sup> (in.)	Vertical Hangers Angles (in.)	Transverse Braces Angle Pipe (Cable Size) <sup>2</sup> (in.)	Horizontal Braces Angles (in.)	Longitudinal Braces Angle (Cable Size) <sup>2</sup> (in.)	Bolt Size (in.)	Connection Type to Structural Members <sup>3</sup>	Max. Wt. Fr <sup>4</sup> (lb)
54×28	L4×4×14ga	L3×3×12ga (D)	L2×2×16ga	L3×3×12ga (E)	3/8	D	14
60×30	L4×4×14ga	L3×3×12ga (E)	L2×2×16ga	L3×3×12ga (F)	3/8	D	39

**NOTES:**

- The ducts' maximum dimensions will govern what bracing is required. Example: A 72 × 30 in. duct will be braced like an 84 × 42 in. duct.
- Provide transverse bracing at 30 ft and longitudinal bracing at 60 ft. See Table 3-2 for cable size.
- See Table 9-1 for "Connection Type" to structural supporting members.
- Maximum weight of duct or combinations of ducts is per linear foot. For ducts weighing more than the maximum weight per foot, use the next higher duct size.

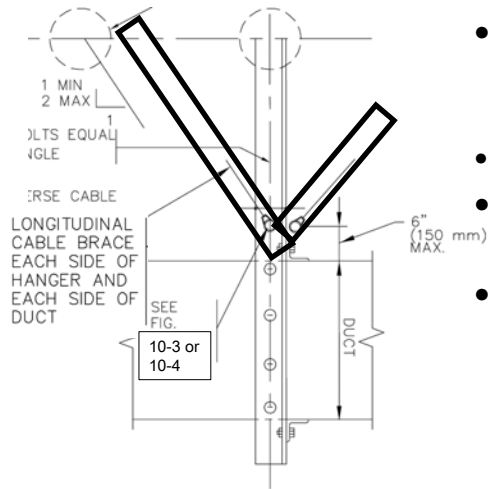
# Example 1

ID	Cable Design Strength					
	Nominal Size		Breaking Strength		Design Strength	
	in	mm	lbf	kN	lbf	kN
A	1/8	3.2	1,330	5.9	466	2.1
B	3/16	4.0	2,140	9.5	749	3.3
C	1/4	4.8	2,850	12.7	998	4.4
D	5/16	5.6	3,850	17.1	1,348	6.0
E	3/8	6.4	4,750	21.1	1,663	7.4
F	1/2	7.1	6,400	28.5	2,240	10.0
G	5/8	7.9	8,000	35.6	2,800	12.5
H	3/4	9.5	10,800	48.0	3,780	16.8
I	7/8	11.1	14,500	64.5	5,075	22.6
J	1	12.7	18,800	83.6	6,580	29.3
K	1 1/8	14.3	24,100	107.2	8,435	37.5
L	1 1/4	15.9	29,600	131.7	10,360	46.1
M	1 3/8	19.1	40,800	181.5	14,280	63.5
N	1 1/2	22.2	55,800	248.2	19,530	86.9
O	1 3/4	25.4	71,900	319.8	25,165	111.9

Table 3-2

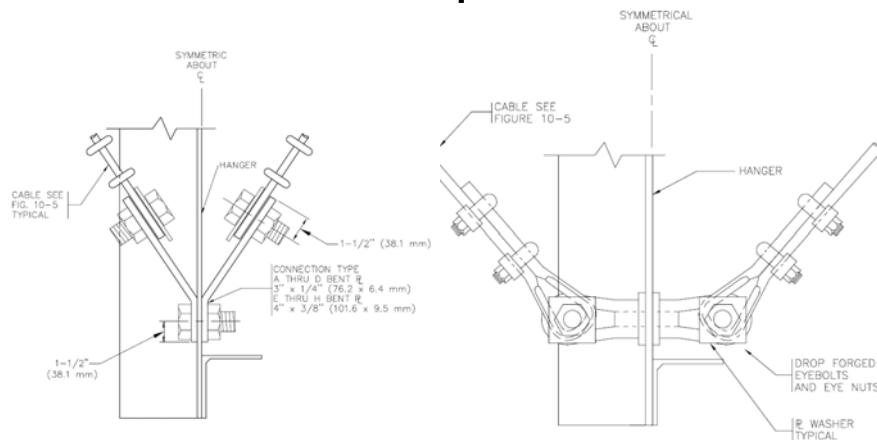
Safety factor ~ 2.85

# Example 1



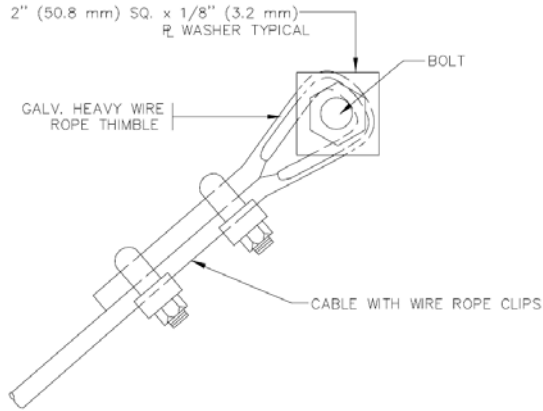
- The longitudinal brace cables are a class F per Table 3-2
- (nominal 9/32" diameter)
- The longitudinal brace spacing is 60 ft.
- Longitudinal cable bracing is on each side of the hanger and on each side of the duct (4)

# Example 1



- Figures 10-3 and 10-4 cable connection to duct hanger

# Example 1



• Figure 10-5 Cable End Connections

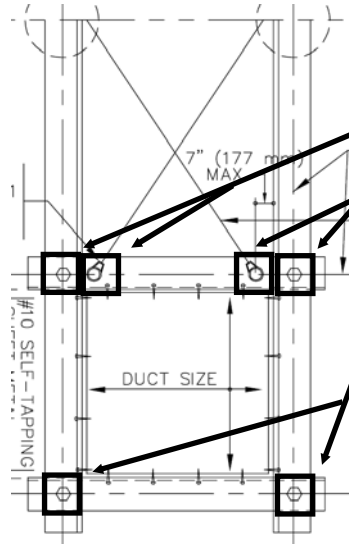
# Example 1

Duct Size W×D <sup>1</sup> (in.)	Vertical Hangers Angles (in.)	Transverse Braces Angle Pipe (Cable Size) <sup>2</sup> (in.)	Horizontal Braces Angles (in.)	Longitudinal Braces Angle (Cable Size) <sup>2</sup> (in.)	Bolt Size (in.)	Connection Type to Structural Members <sup>3</sup>	Max. Wt. Ft <sup>4</sup> (lb)
54×28	L4×4×14ga	L3×3×12ga (D)	L2×2×16ga	L3×3×12ga (E)	3/8	D	34
<b>60×30</b>	L4×4×14ga	L3×3×12ga (E)	L2×2×16ga	L3×3×12ga (F)	3/8	D	<b>39</b>

**NOTES:**

1. The ducts' maximum dimensions will govern what bracing is required. Example: A 72 × 30 in. duct will be braced like an 84 × 42 in. duct.
2. Provide transverse bracing at 30 ft and longitudinal bracing at 60 ft. See Table 3-2 for cable size.
3. See Table 9-1 for "Connection Type" to structural supporting members.
4. Maximum weight of duct or combinations of ducts is per linear foot. For ducts weighing more than the maximum weight per foot, use the next higher duct size.

# Example 1



- Connection bolts are 3/8 inch diameter

# Example 1

Duct Size WxD <sup>1</sup> (in.)	Vertical Hangers Angles (in.)	Transverse Braces Angle Pipe (Cable Size) <sup>2</sup> (in.)	Horizontal Braces Angles (in.)	Longitudinal Braces Angle (Cable Size) <sup>2</sup> (in.)	Bolt Size (in.)	Connection Type to Structural Members <sup>3</sup>	Max. Wt. Ft <sup>4</sup> (lb)
54x28	L4x4x14ga	L3x3x12ga (E)	L2x2x16ga	L3x3x12ga (E)	%	D	34
<b>60x30</b>	L4x4x14ga	L3x3x12ga (E)	L2x2x16ga	L3x3x12ga (F)	%	D	39

**NOTES:**

1. The ducts' maximum dimensions will govern what bracing is required. Example: A 72 x 30 in. duct will be braced like an 84 x 42 in. duct.
2. Provide transverse bracing at 30 ft and longitudinal bracing at 60 ft. See Table 3-2 for cable size.
3. See Table 9-1 for "Connection Type" to structural supporting members.
4. Maximum weight of duct or combinations of ducts is per linear foot. For ducts weighing more than the maximum weight per foot, use the next higher duct size.

# Example 1

Type	Maximum Load Capacity <sup>1</sup> (lb)	Expansion Anchors to Concrete <sup>2,6</sup> (in.)	Machine Bolt End of Brace (in.)	Spreader Size (in. x lb/ft)	Machine Bolt at Wood <sup>3</sup> (in.)	Hollow Core Plank Rod (in.)	Angle Supporting Structural Member <sup>4,5</sup> (in.)
A	1040	½	¾	C4×5.4	½	¾	3½×2½×½×0 ft, 3 in. LLH
B	1415	¾	¾	C4×5.4	¾	¾	5×3×½×0 ft, 3 in. LLH
C	1586	(2) ½	¾	C5×6.7	¾	¾	(2) 4×3×½×0 ft, 4 in. LLH
D	2020	(2) ¾	¾	C6×8.2	Note <sup>5</sup>	½	(2) 5×3×½×0 ft, 4 in. LLH
E	2870	(2) ¾	¾	C8×11.5	Note <sup>5</sup>	½	(2) 6×3½×½×0 ft, 4 in. LLH
F	4600	(4) ¾	¾	C9×13.4	Note <sup>5</sup>	Note <sup>5</sup>	(2) 5×3×¾×0 ft, 10 in. LLH
G	7040	(4) ¾	¾	C10×15.3	Note <sup>5</sup>	Note <sup>5</sup>	(2) 6×3½×½×0 ft, 11½ in. LLH
H	9240	(4) ¾	1	C12×20.7	Note <sup>5</sup>	Note <sup>5</sup>	(2) 8×4×¾×1 ft, 1½ in. LLH
I	15,650	(6) ¾	1	C12×30	Note <sup>5</sup>	Note <sup>5</sup>	(2) 8×4×¾×2 ft, 2½ in. LLH

**Table 9-1 Schedule for Typical Connections to Structural Supporting Members<sup>1</sup>**

NOTES:

5 typical (10)

# Example 1

NOTES:

1. Maximum load capacity is for general information only and the maximum member force in the bracing system used in this manual. A designer may use this force to design a special connection if required.
2. Expansion anchors will be installed per the requirements given in the latest ICC report for the specific anchor. Also, see the requirements and general notes in Chapter 3.
3. Machine bolts into 6x wood members unless shown otherwise on the details.
4. LLH = long leg horizontal.
5. Must be engineered individually.
6. Numbers in parentheses are the quantity required. (2) ¾ is two ¾ in. diameter anchors.



# Example 1

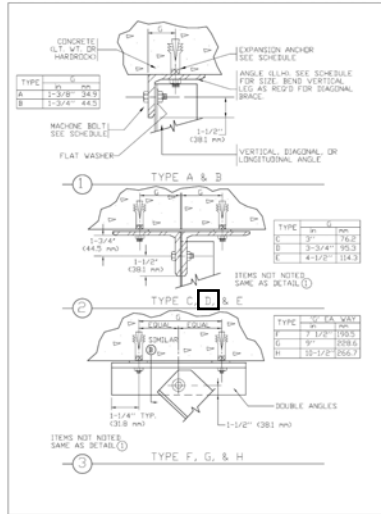
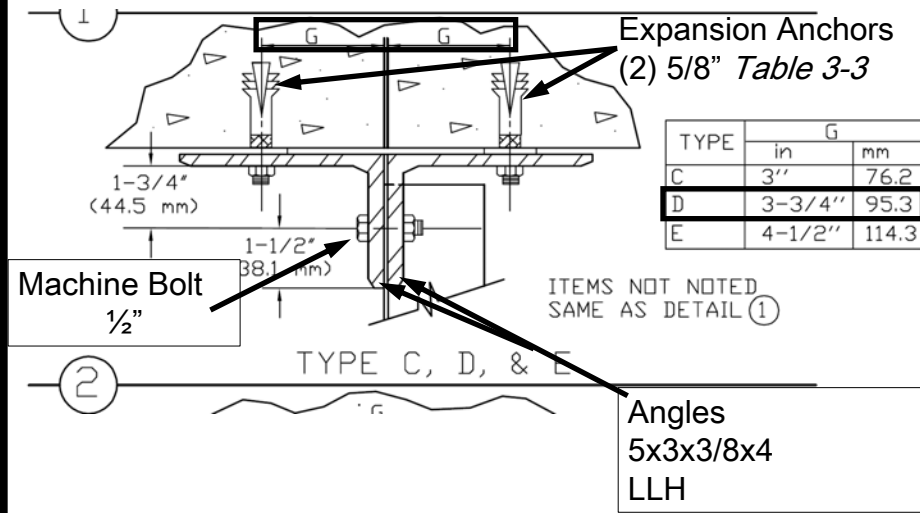


FIGURE 9-1 CONNECTIONS TO CONCRETE

- Chapter 9 has other “typical” connections including:
- Steel
  - Web
  - I BEAMS (SPREADERS)
- concrete decking
- hollow core plank

# Example 1



## $C_s > 1.00$

- What happens if  $C_s$  is greater than 1?
- Appendix A
  - $C_s = 1.15$
  - Use SHL A where  $C_s = 1.00$  and adjust spacing accordingly.



## $C_s > 1.00$

- Spacing for SHL A = 30 ft.
  - Reduce the spacing by
    - »  $C_s A / C_s X$
    - »  $(1.00 / 1.15) = .87$
  - $.87 \times 30 \text{ ft} = 26 \text{ ft.}$
  - Brace using SHL A but use 26 ft. spacing



# Thank You

***Technical Inquiries:***  
**[www.smacna.org](http://www.smacna.org)**

***click “Technical Services”***

***click “Technical Inquiries”***

***<http://www.smacna.org/technical/index.cfm?fuseaction=inquiry>***

